

MG 3 (2024-)

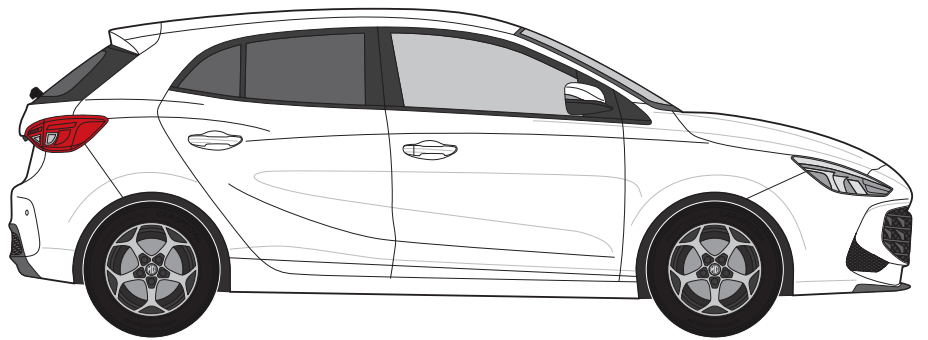

MG 3 (2024-)

R55

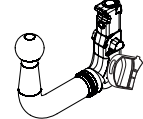
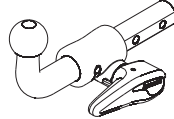
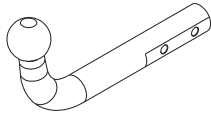

TowCar enganches **aragon**

E1 APPROVALNUMBER **55R-02 3508** D-VALUE D **6,6** kN

TYPE **MGM006** CLASS **A50-X** MAX.VERT.LOAD S **80** kg

TowCar enganches **aragon**

E1 APPROVALNUMBER **55R-02 3508** D-VALUE D **6,6** kN

TYPE **MGM006** CLASS **A50-X** MAX.VERT.LOAD S **80** kg

TowCar enganches **aragon**

E1 APPROVALNUMBER **55R-02 3504** D-VALUE D **6,6** kN

TYPE **MGM007** CLASS **A50-X** MAX.VERT.LOAD S **80** kg

D=6,6 kN



S= 80 kg

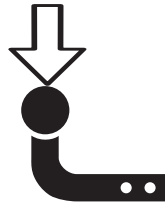

*T 1000 Kg



N/m	8,8	10,9	12,9
M6	10	15	18
M8	24	36	42
M10	51	75	87
M12	87	130	147
M14	138	198	231
M16	200	289	341

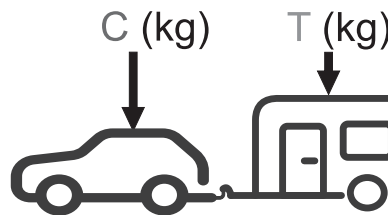

$g = 9,81 \text{ m/s}^2$

$$D \geq \frac{T \cdot C}{T+C} \cdot \frac{g}{1000} \text{ (kN)}$$

$$T \leq \frac{C \cdot D \cdot 1000}{(C \cdot g) - (1000 \cdot D)} \text{ (kg)}$$

*El MMR (T) puede variar dependiendo del vehículo.

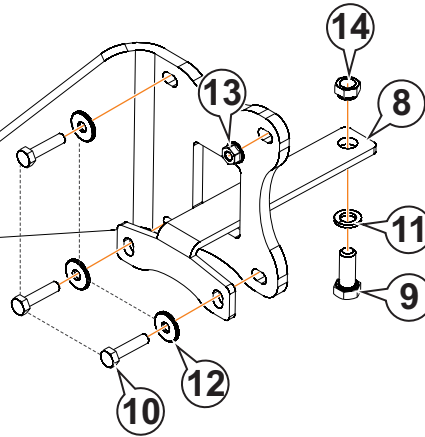
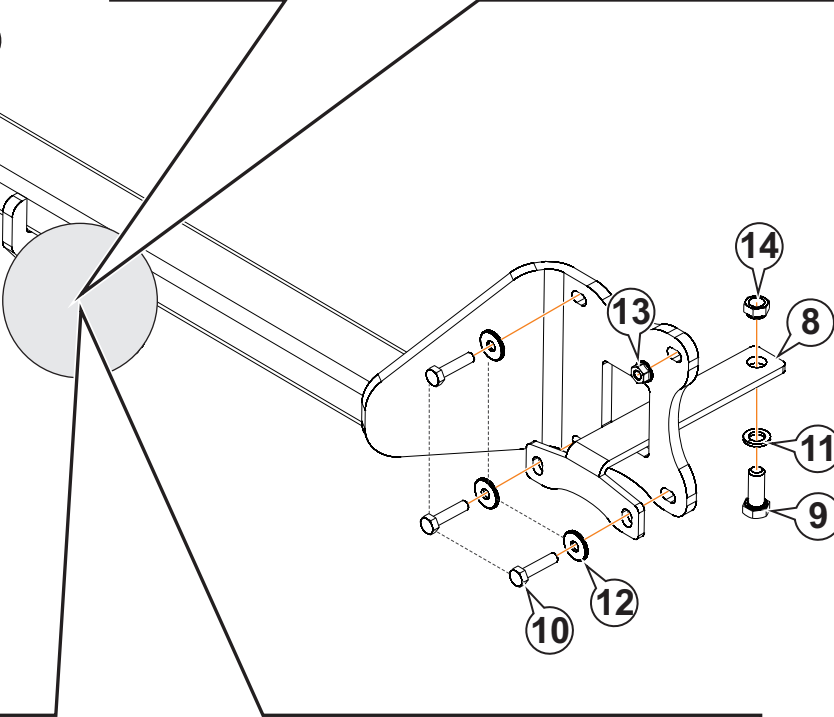
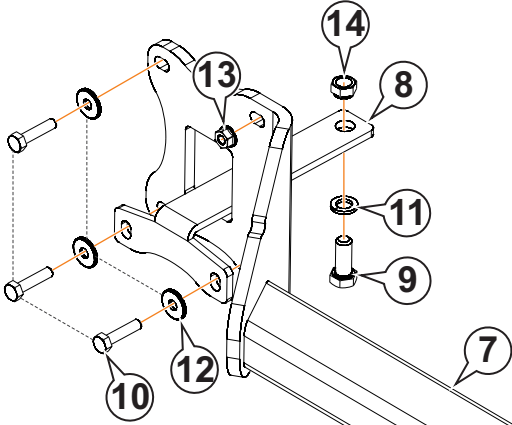
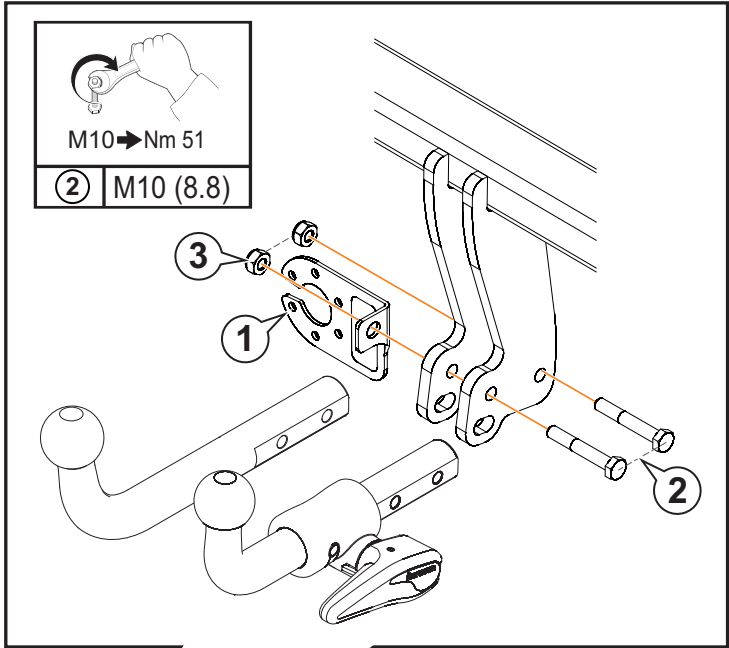
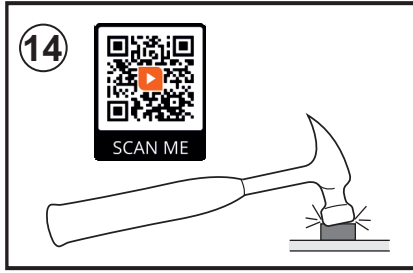











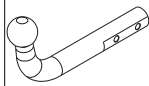

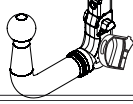

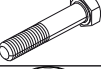
Wiring kit

4, 5, 6, F1, F2, F3, F4

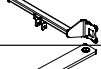
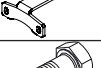
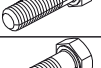
	#	
F1	M12 x 25 DIN 933	3
	Ø12 Grower DIN 128	3
F2	M12 x 35 DIN 933	1
	Ø12 Grower DIN 128	1
	M6 x 25 DIN 7380	1
F3	Ø6 DIN 125	1
	Ø8 DIN 9021	1
	M6 DIN 985	1
F4	M5 x 35 DIN 7985	3

M12 → Nm 87
M10 → Nm 51

F1 M12 (8.8)
F2 M12 (8.8)
F3 M6 (8.8)
F4 M5 (8.8)

					
1		AEV0005	1		
2		M10x65 DIN 931 (8.8)	2		
3		M10 DIN 985	2		
4		AEV0073			1
5		AEV0072			1
6		AEV0006			1
7		C7006AX60	1		1
8		C7006AA22	2		2
9		M12x30 DIN 933 (8.8)	2		2
10		M8x35 DIN 933 (8.8)	6		6
11		Ø12 DIN 128A	2		2
12		Ø8 DIN 9021	6		6
13		M8 DIN 6923	2		2
14		KALEI M12	2		2

1



5 min.

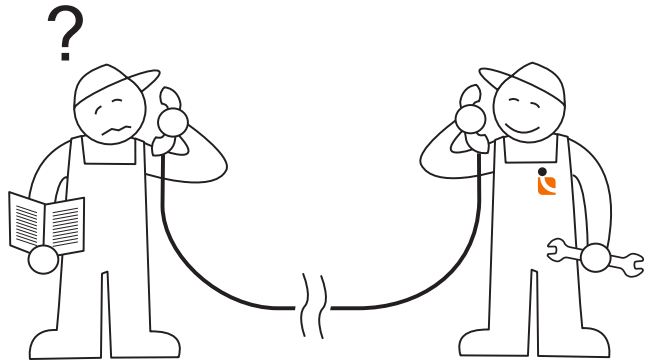

Tel.: (+34) 976 457 130

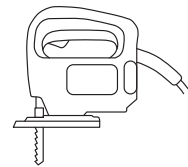
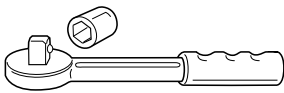
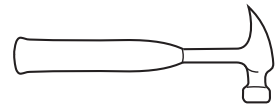
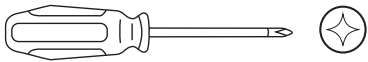

2

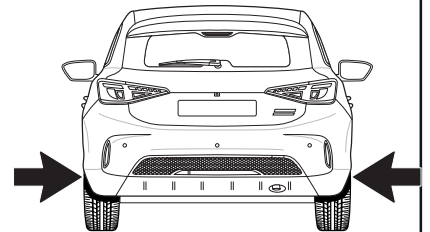
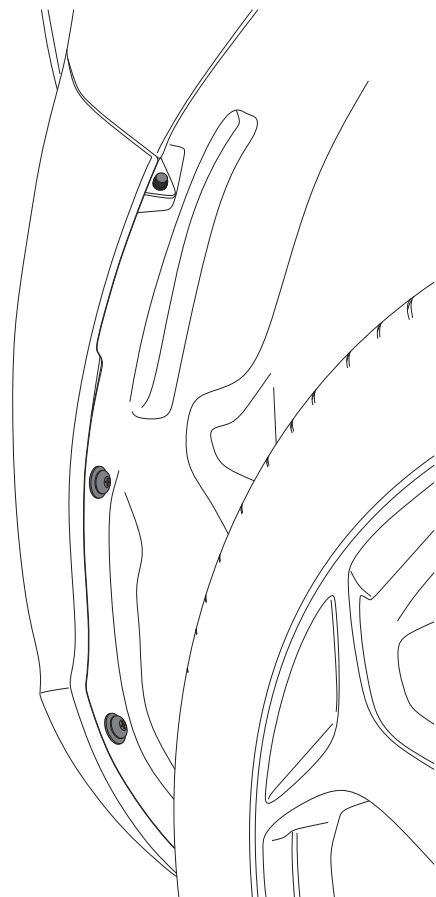

3x

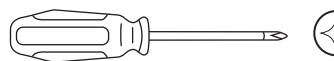
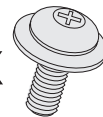

3

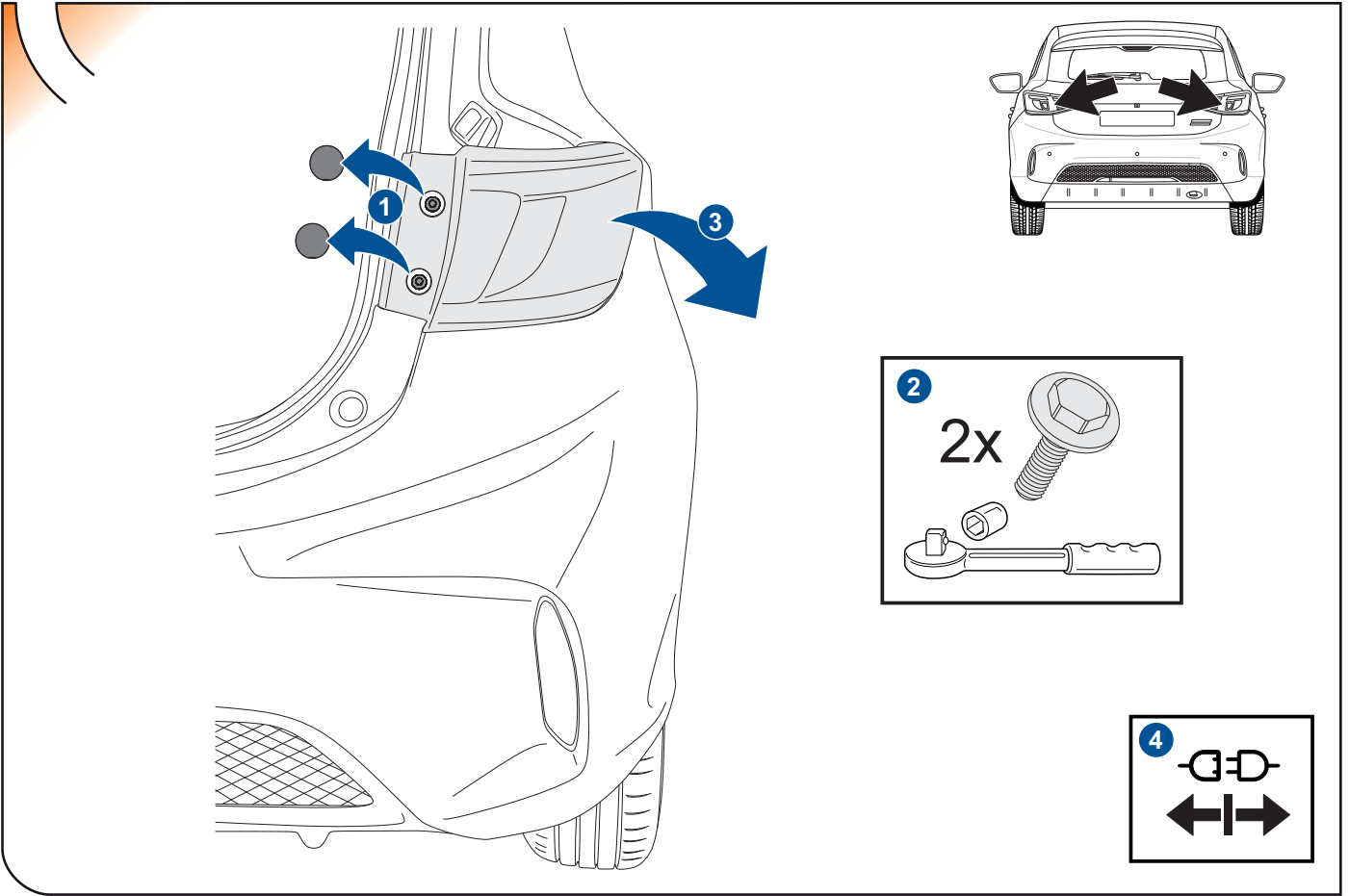

4

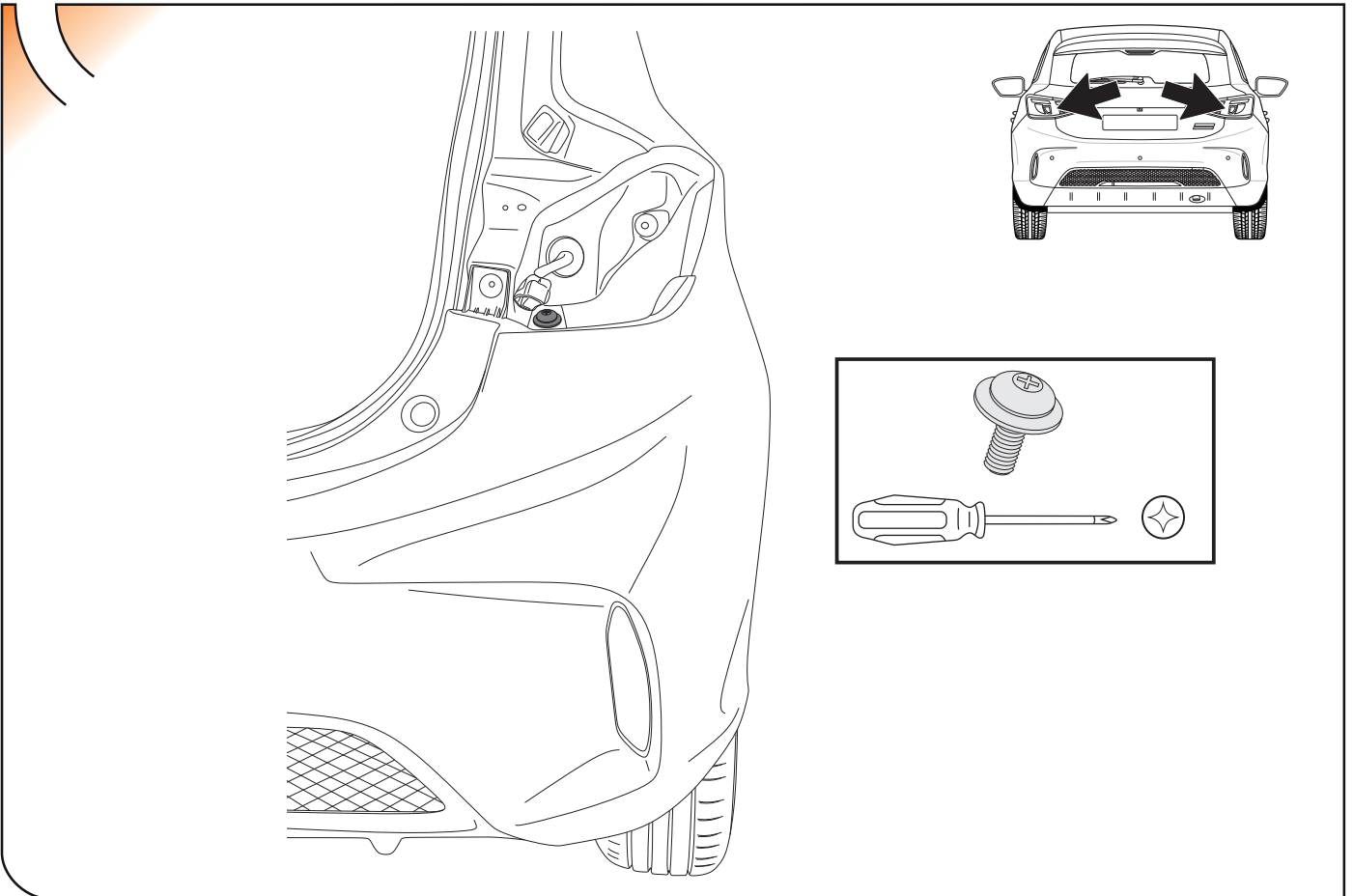

5

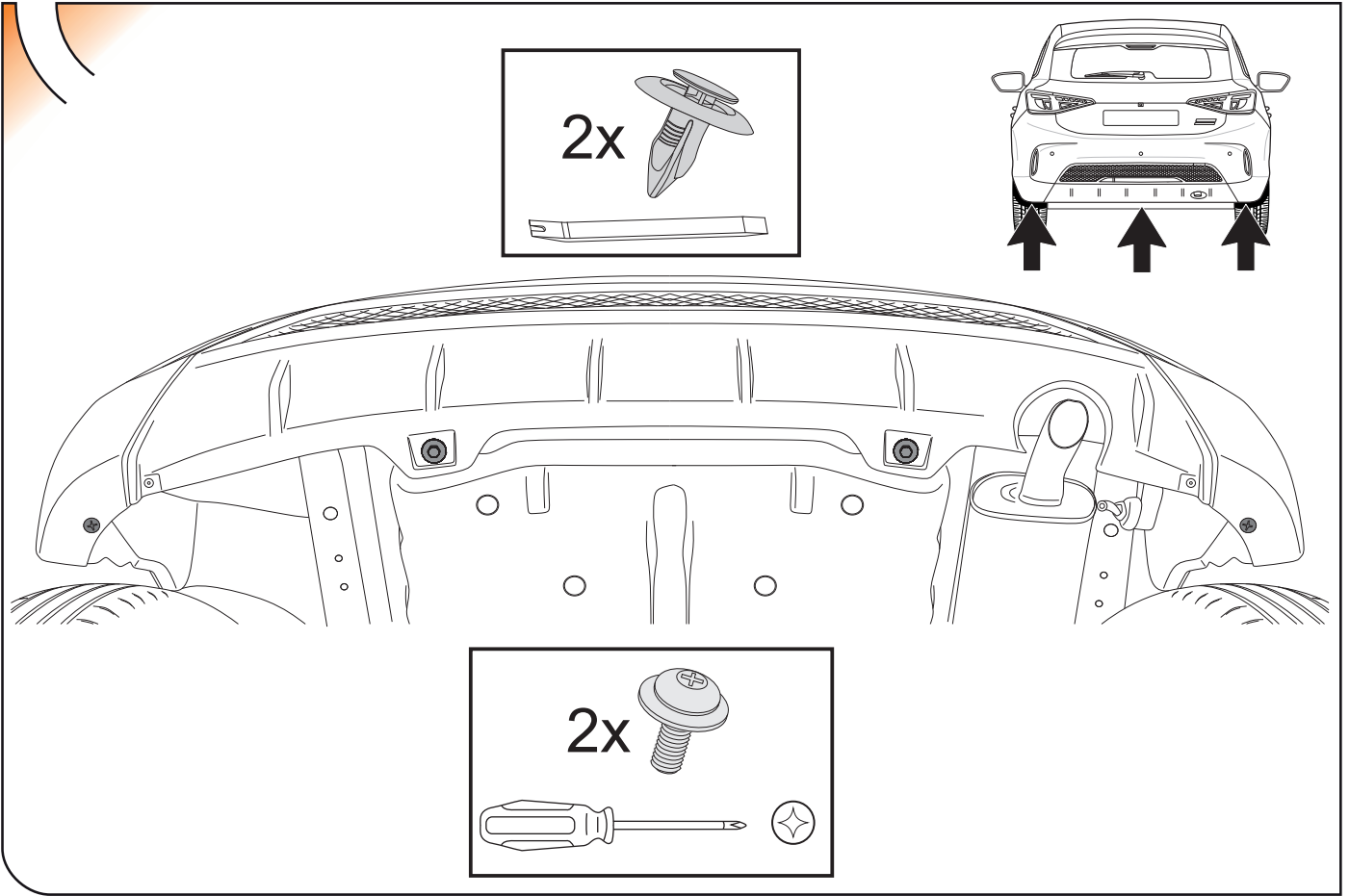

6

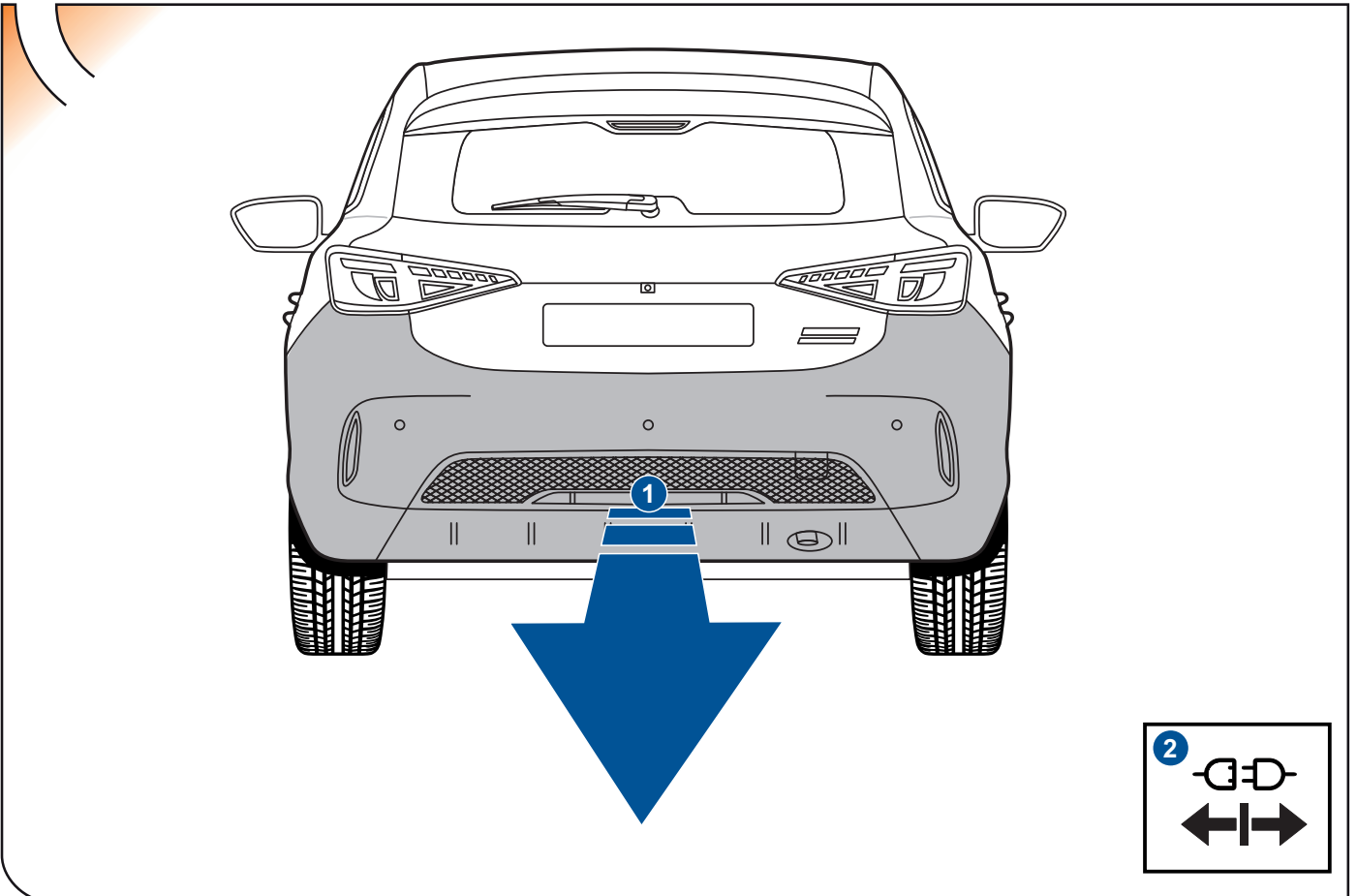

7

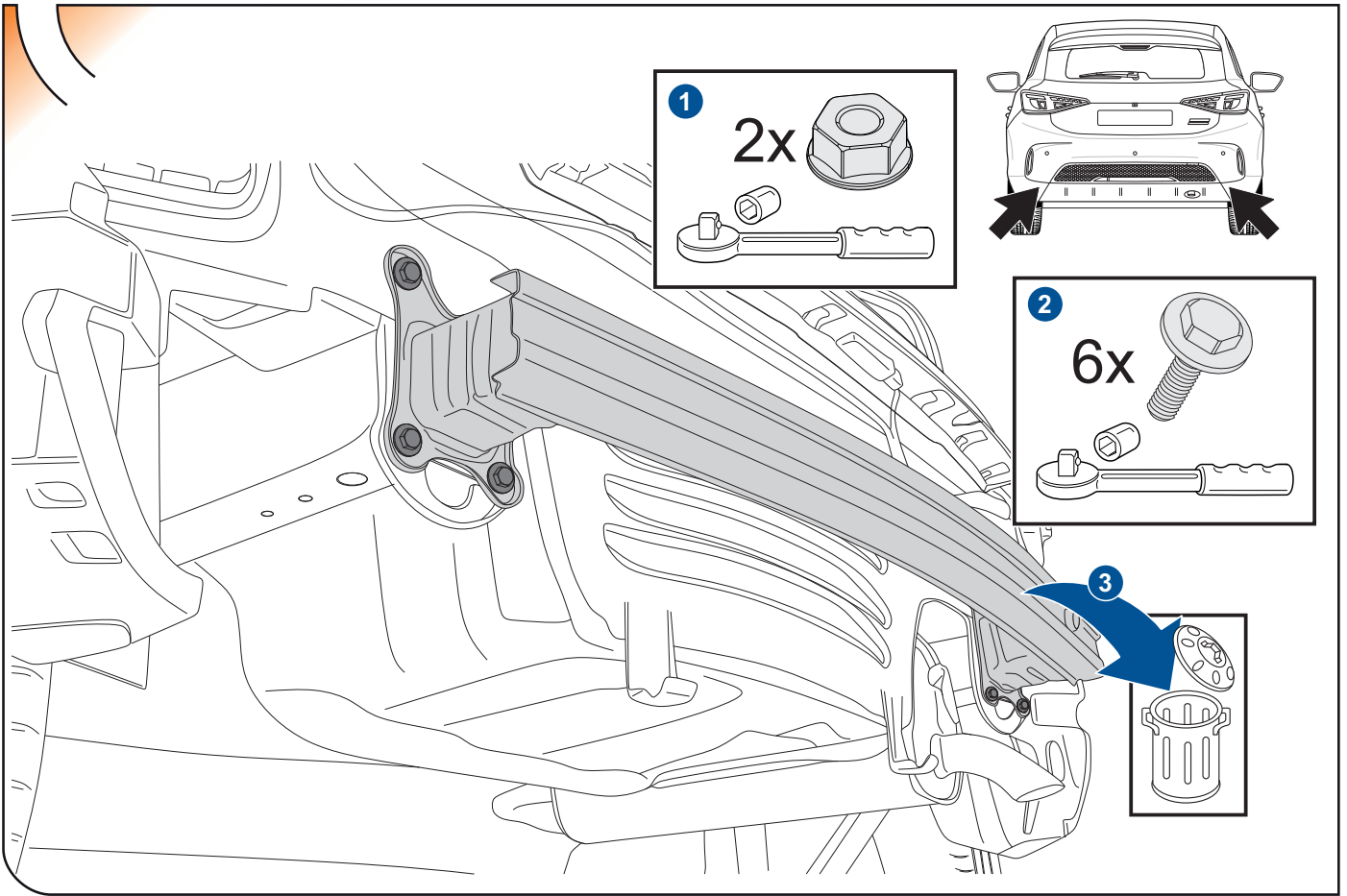

8

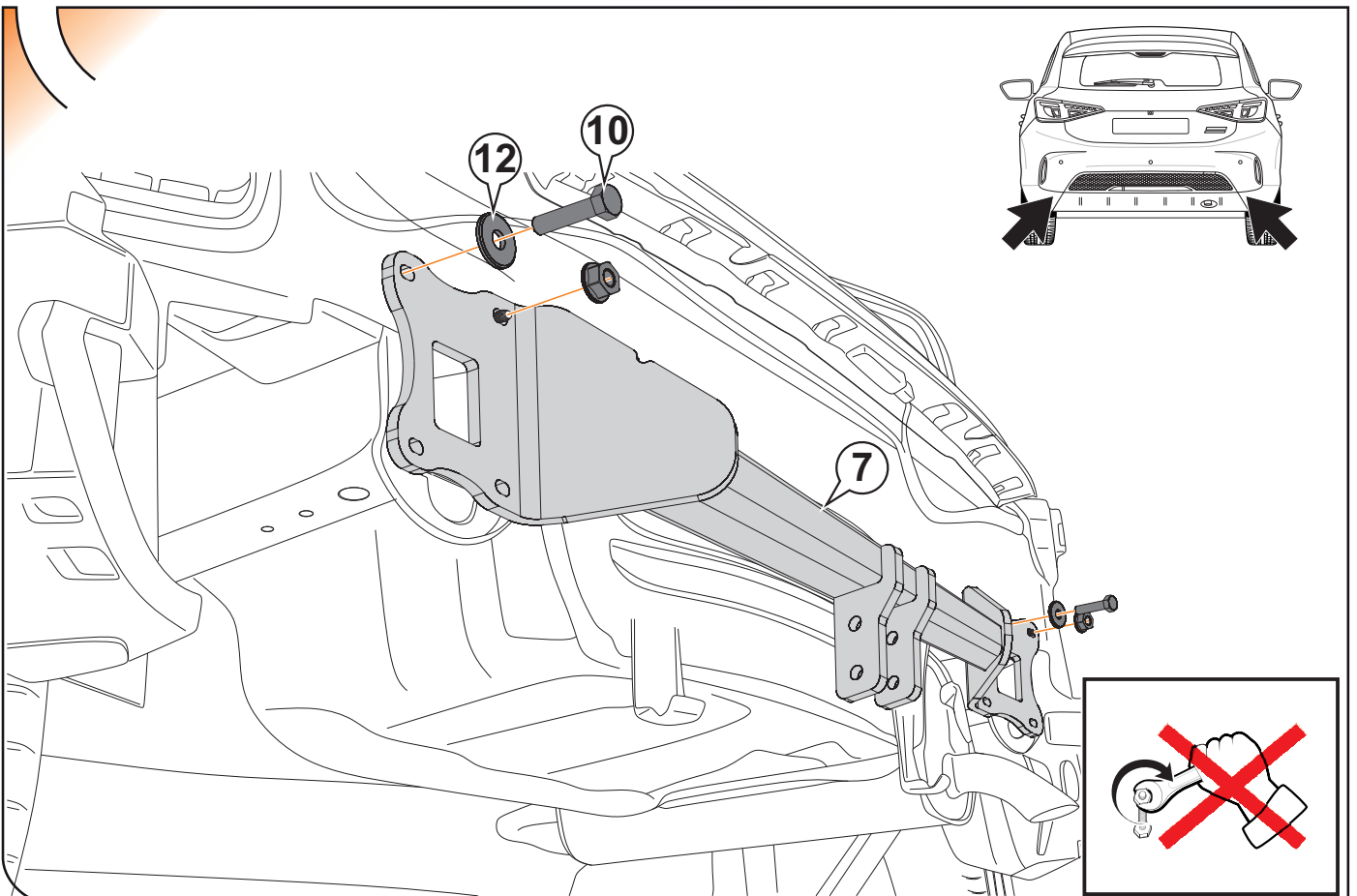

9

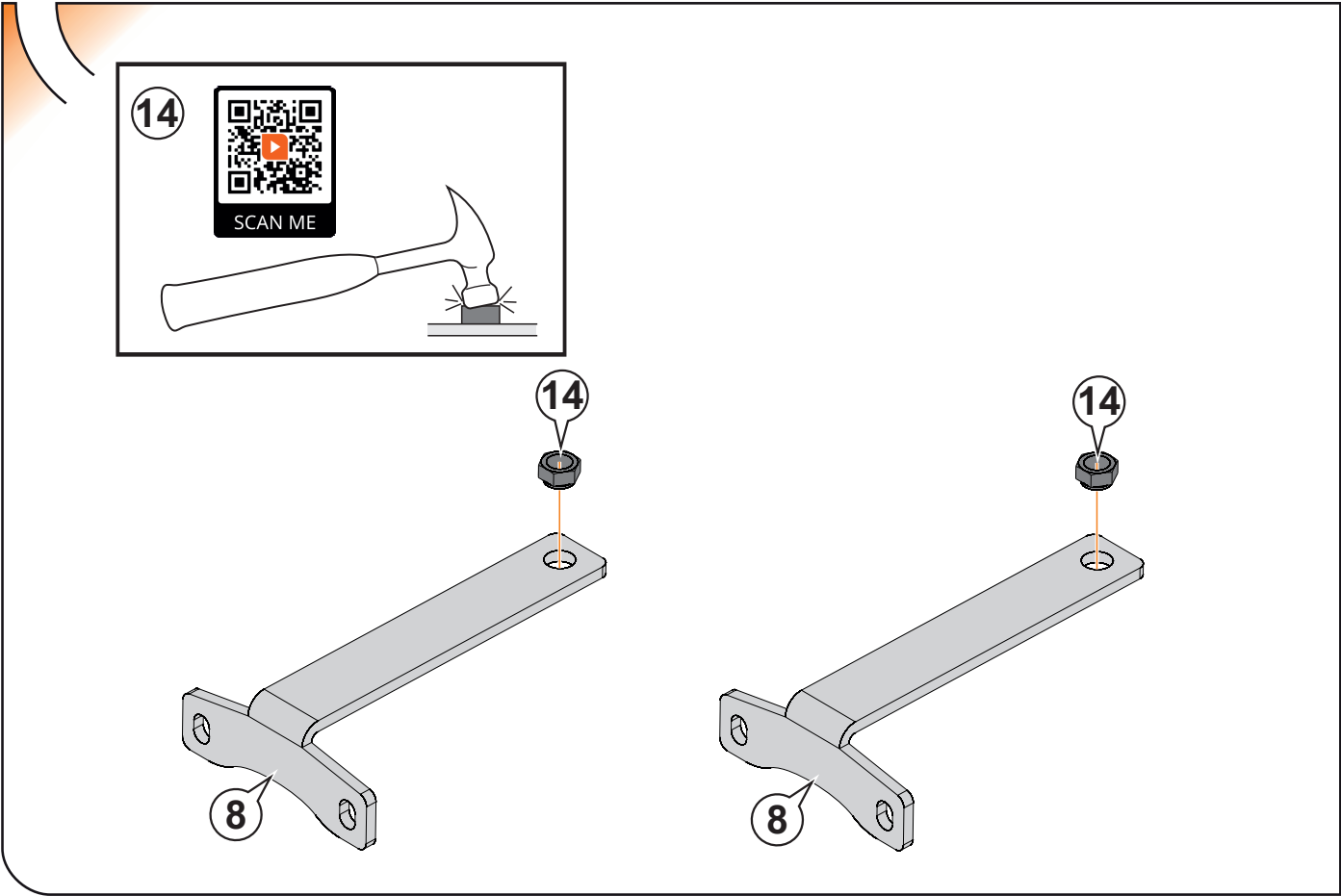

10

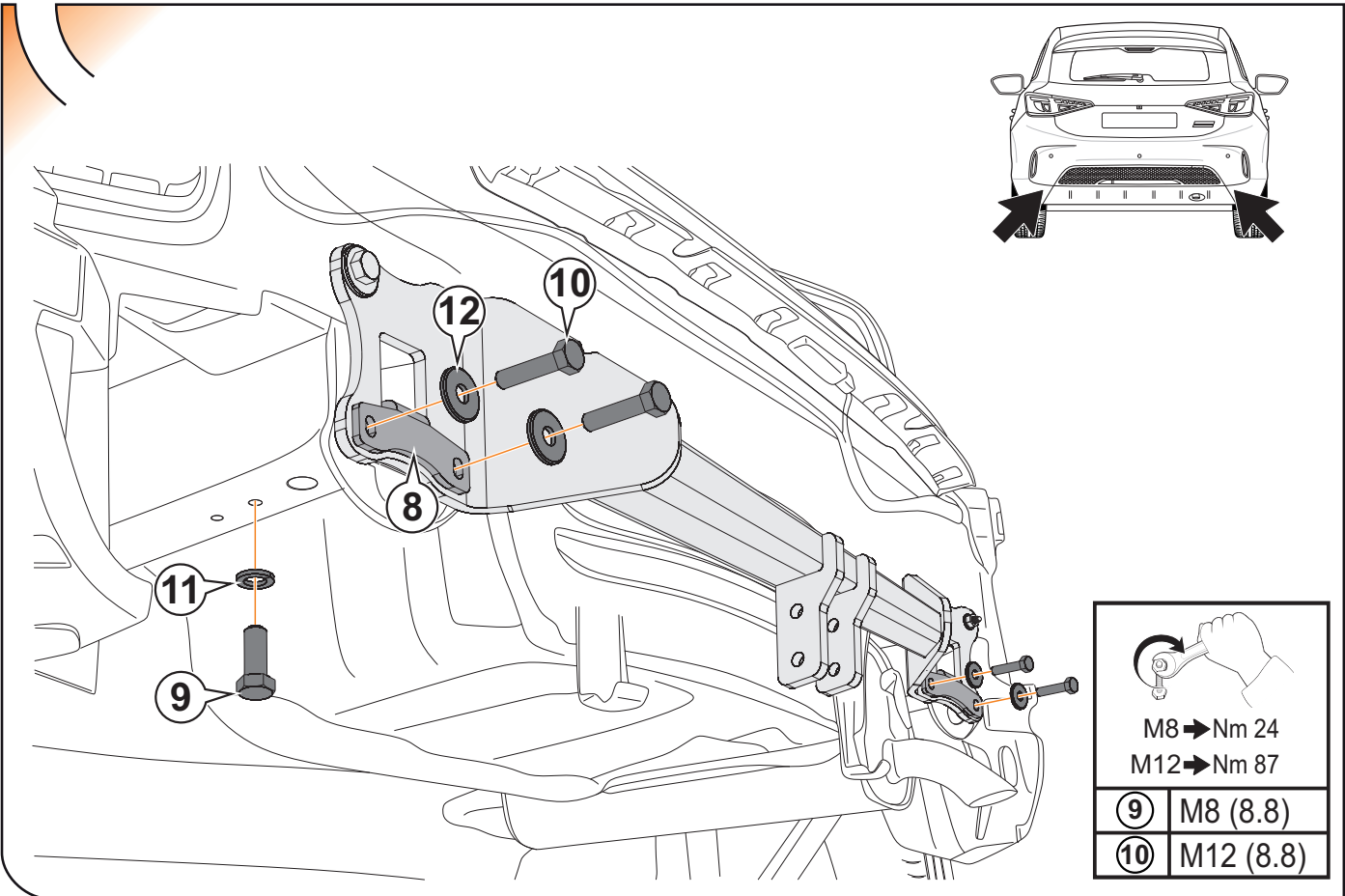

11

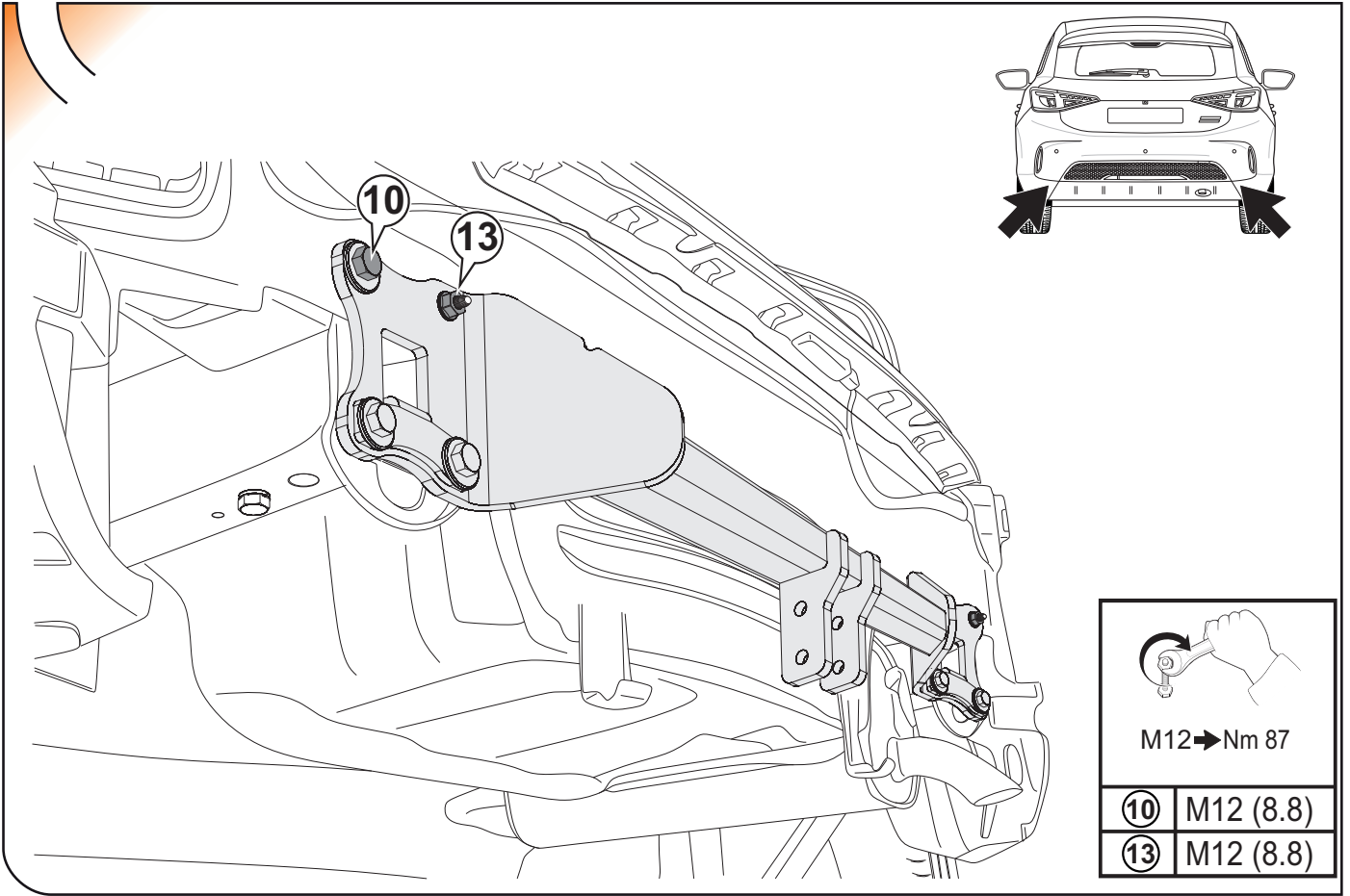

12

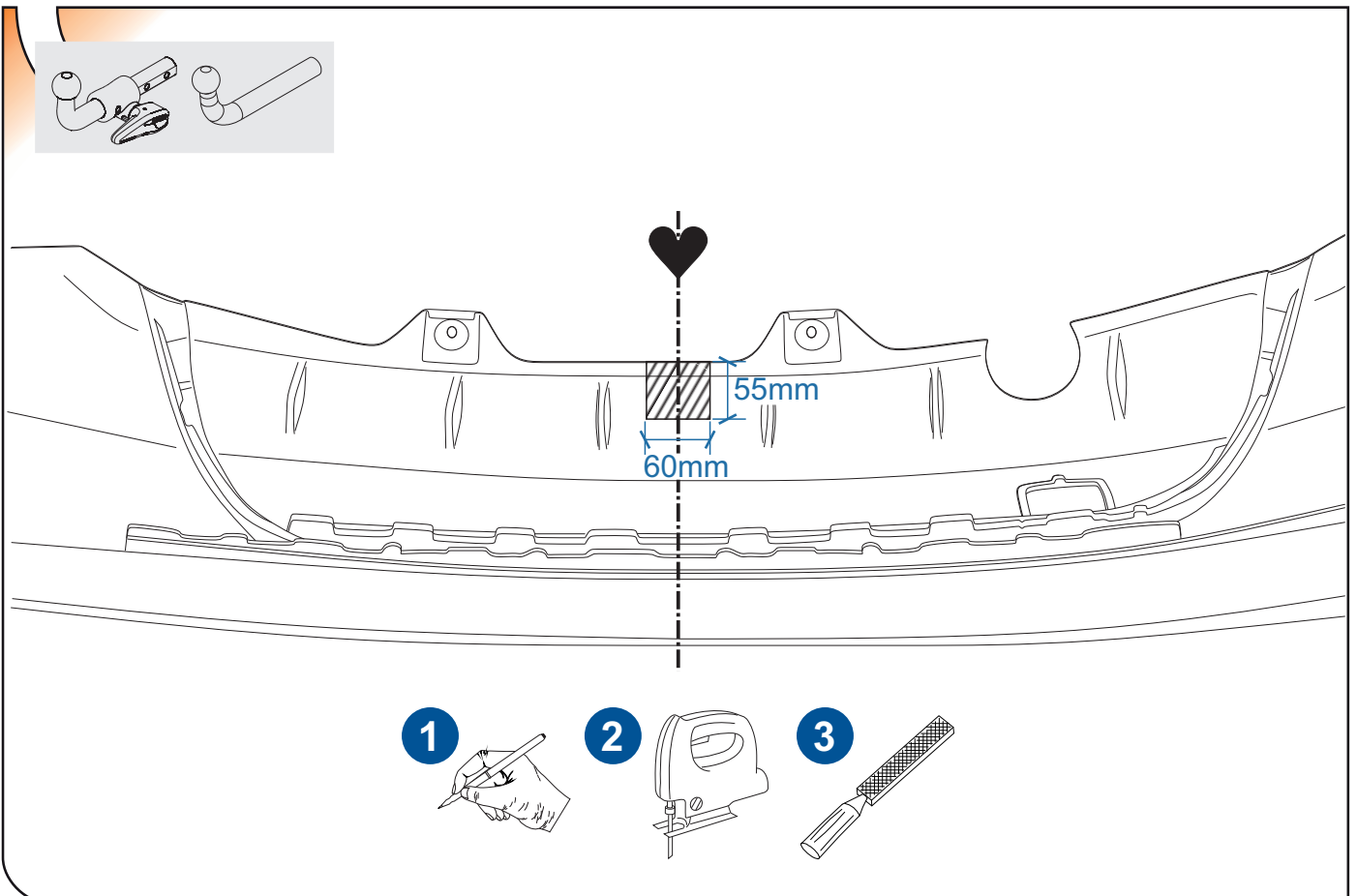

13

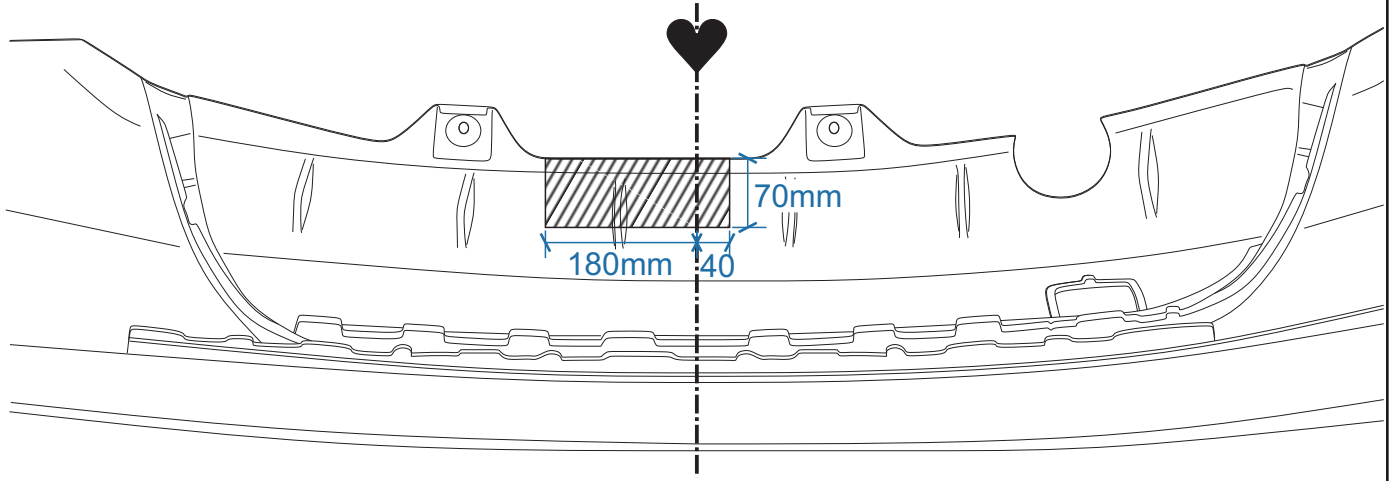
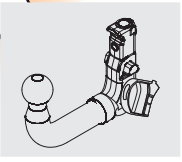

- 1
- 2
- 3

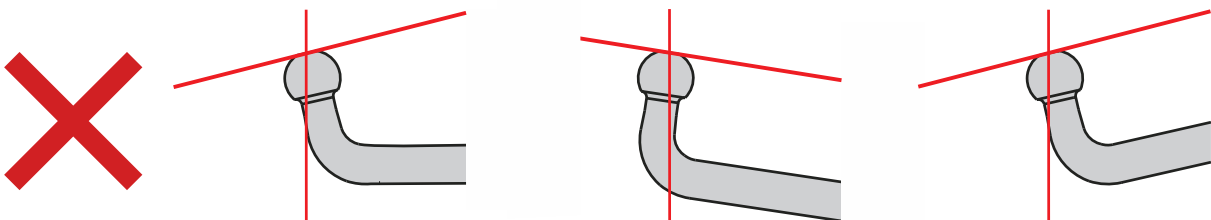
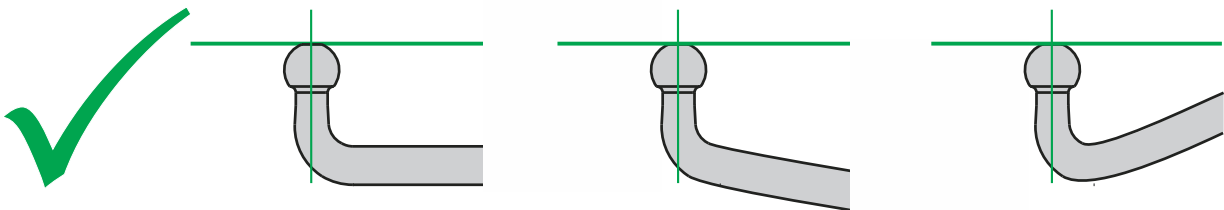

IN

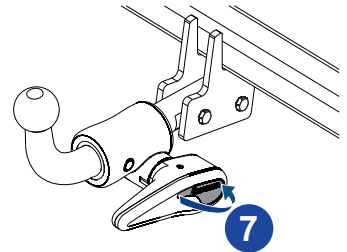
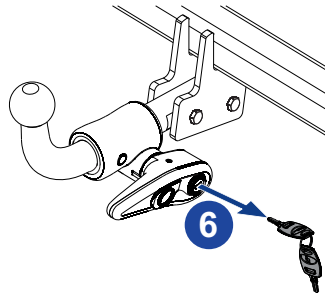
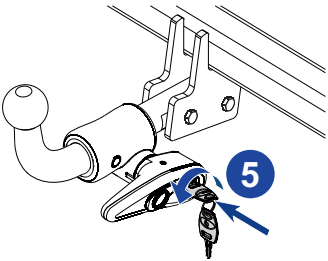
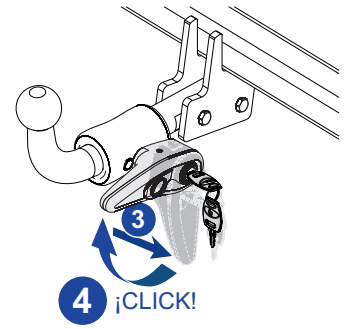
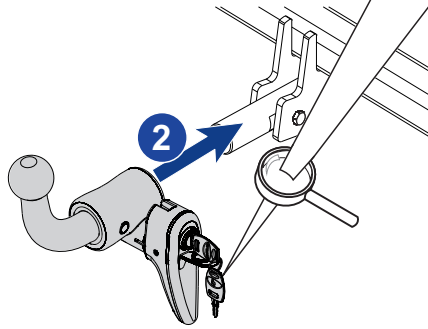
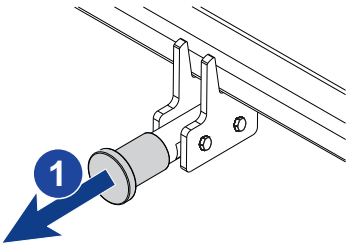
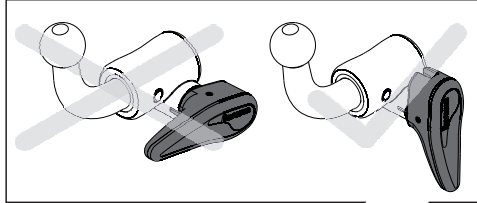

OUT

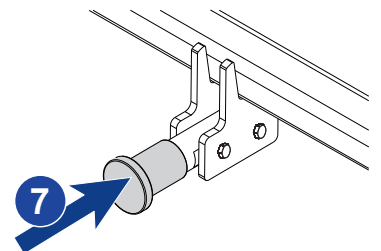
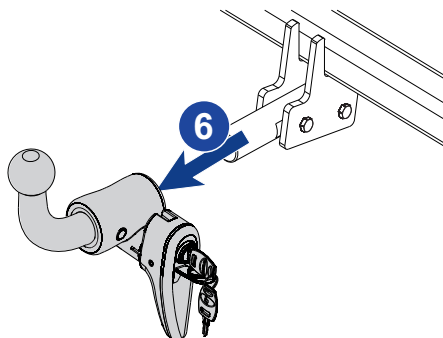
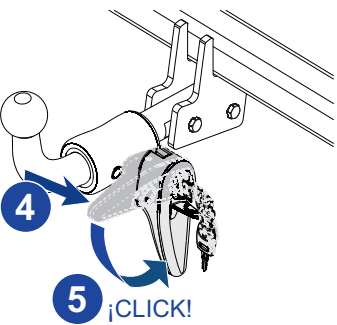
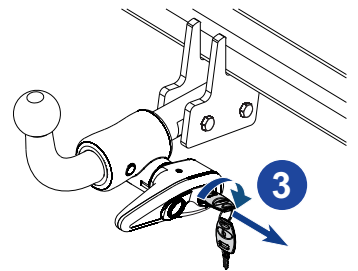
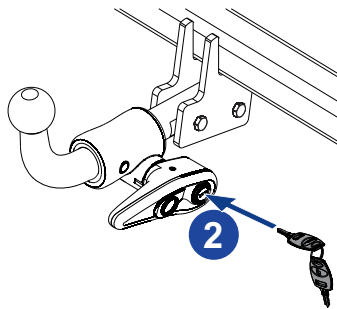
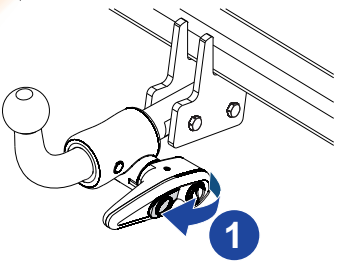

IN

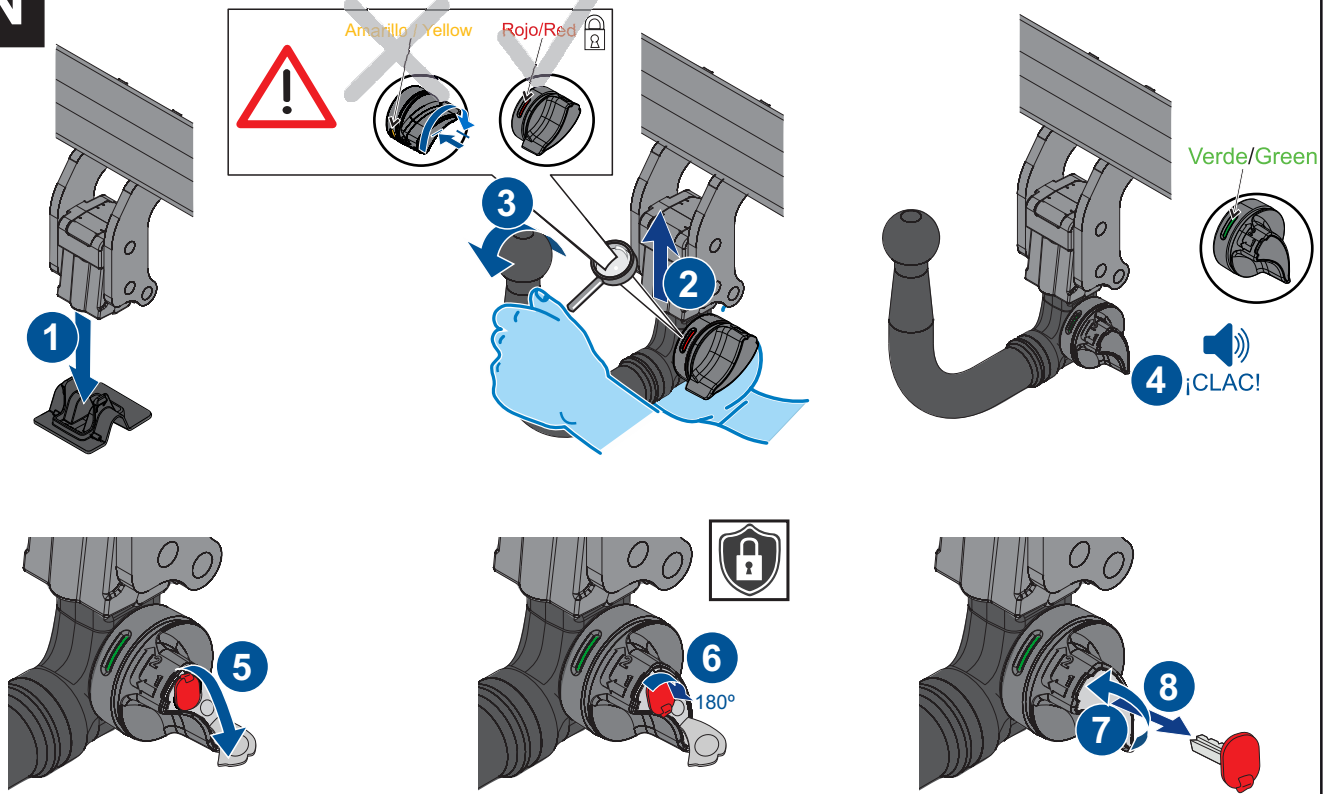

OUT

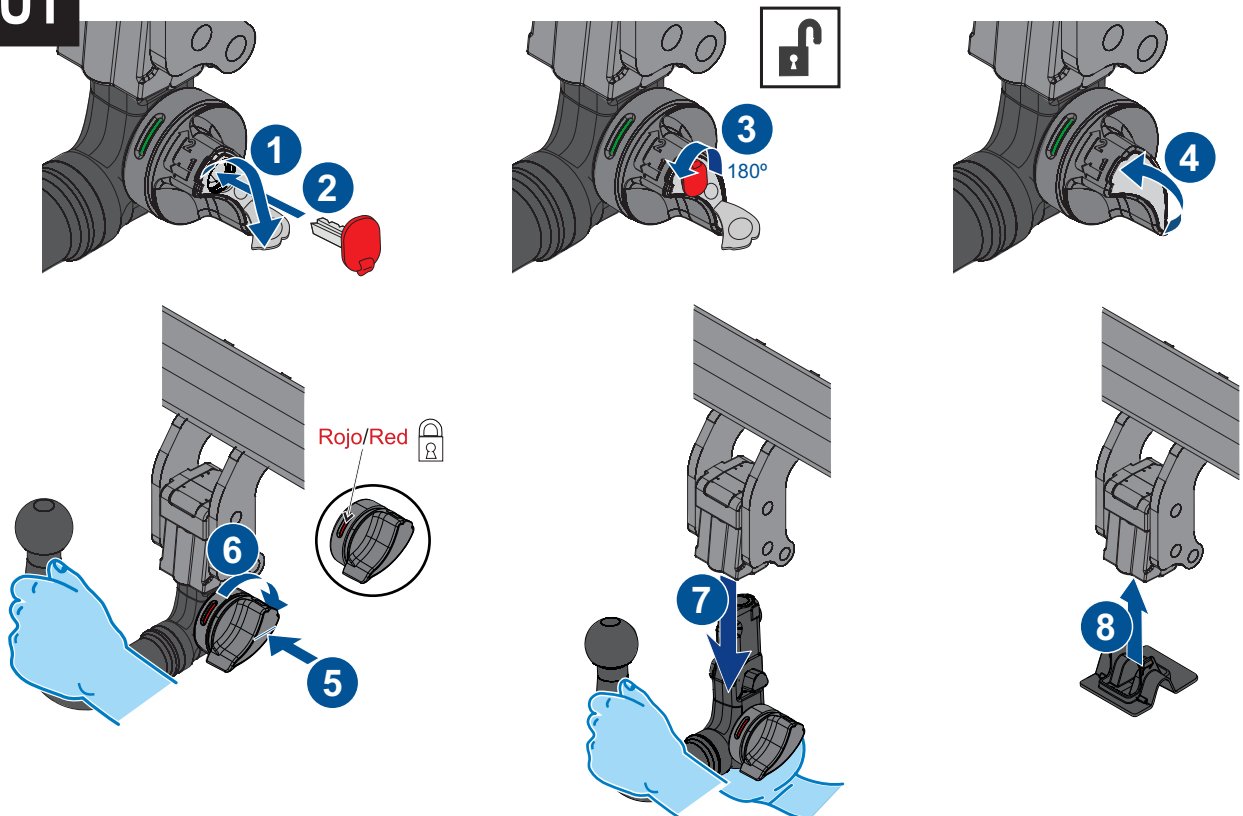

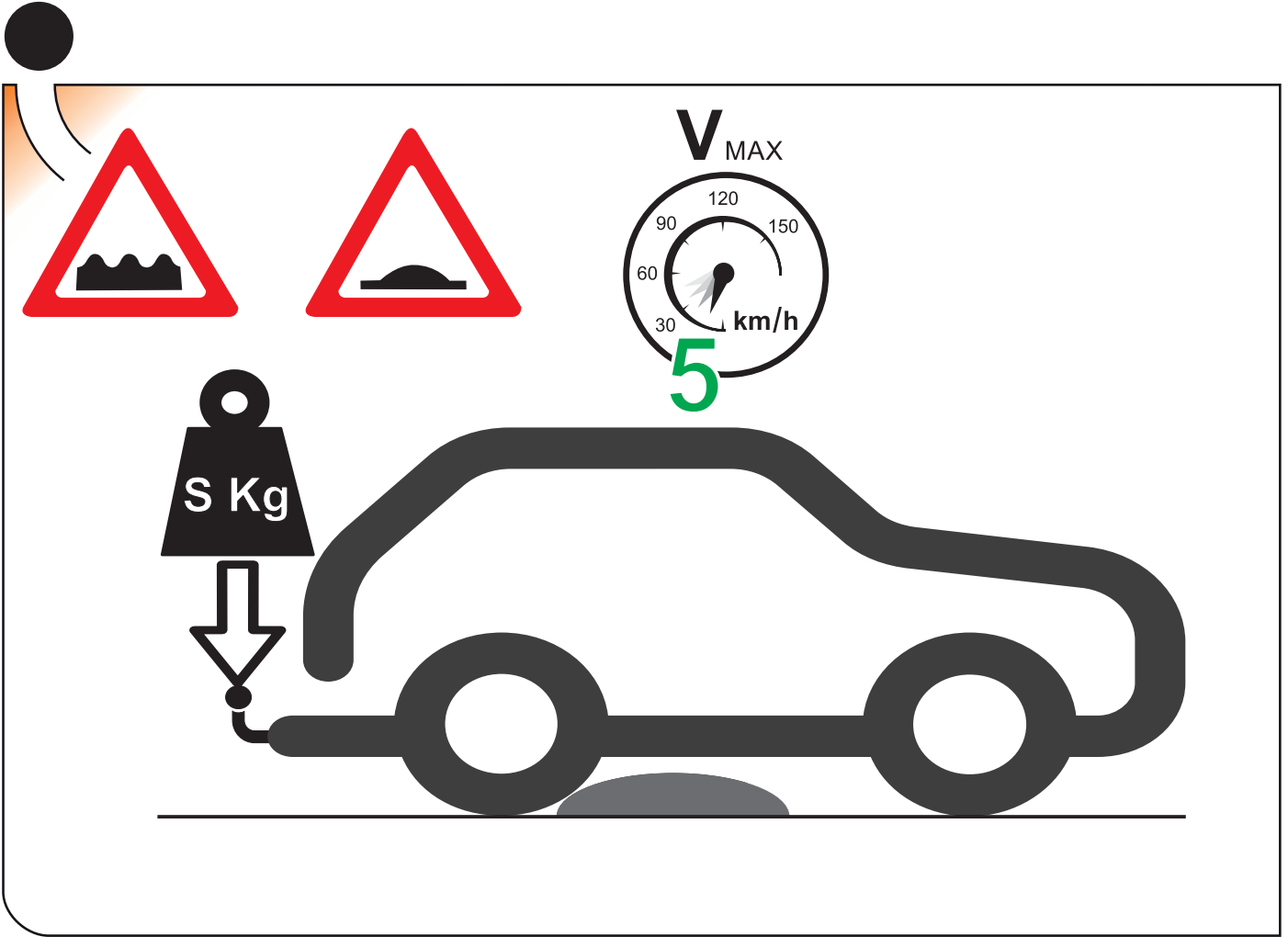



ANEXO III

CERTIFICADO DE TALLER

D. _____, expresamente autorizado por la empresa _____
domiciliada en _____, teléfono _____, dedicada
a la actividad de _____ n° de Registro Industrial _____ y n° de registro
especial (1)_____.

CERTIFICA

Que la mencionada empresa ha realizado la/s Reforma/s y asume la responsabilidad de la ejecución,
sobre el vehículo marca....., tipo.....
variante..... denominación comercial
matrícula y n° de bastidor, de acuerdo con:

- La normativa vigente en materia de reformas de vehículos.
- Las normas del fabricante del vehículo aplicables a la/s reforma/s llevadas a cabo en dicho vehículo.
- El proyecto descriptivo de la/s reforma/s, adjunto al expediente.

OBSERVACIONES: (2)

Tipificada/s con el código de reforma/s.....
Reforma consiste en:

COLOCACION DE ENGANCHE HOMOLOGADO EUROPEO MARCA:

n° de identificación / marca de homologación:

Type :

Garantizo que se cumple lo previsto en el artículo 6 del Reglamento General de vehículos y, en su caso, en el artículo 9 del R.D. 1457/1986, de 10 de enero, por el que se regula la actividad industrial en talleres de vehículos automóviles, de equipos y sus componentes, modificado por 455/2010 de 16 de abril.

....., a.....de.....de

Firma y sello:

(1) En el caso de que la reforma sea efectuada por el fabricante se indicará N/A.

(2) Se debe especificar en este apartado OBSERVACIONES, la identificación de los equipos o sistemas modificados.

ES

1

ANEXO III
CERTIFICADO DE TALLER



2

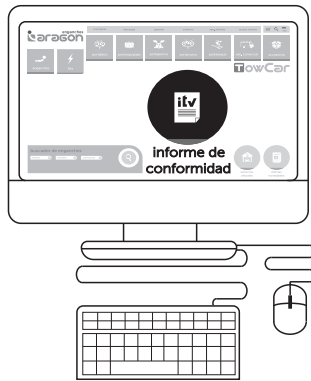

3



IT

1

DICHIARAZIONE DI CORRETTO MONTAGGIO

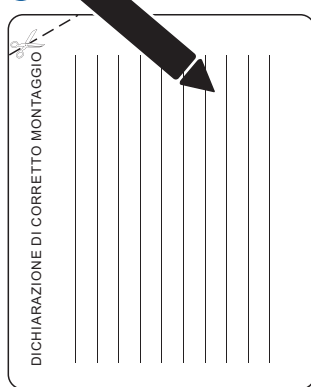

2

