

Suzuki Swift (2024-)

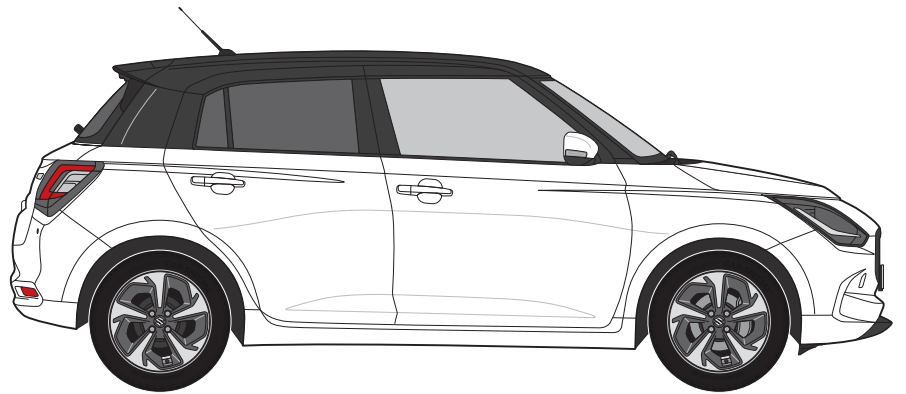

Suzuki Swift (2024-)

R55

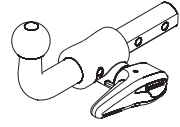

TowCar enganches **aragon**

| | | |
|----------------|----------------|---------------|
| E ₉ | APPROVALNUMBER | D-VALUE |
| | 55R-02 2889 | D 6,6 kN |
| | TYPE | CLASS |
| | SUZ039 | A50-X |
| | | MAX.VERT.LOAD |
| | | S 80 kg |

D=6,6 kN



S= 80 kg

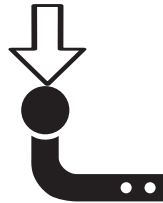

*T 1210 Kg



| N/m | 8,8 | 10,9 | 12,9 |
|-----|-----|------|------|
| M6 | 10 | 15 | 18 |
| M8 | 24 | 36 | 42 |
| M10 | 51 | 75 | 87 |
| M12 | 87 | 130 | 147 |
| M14 | 138 | 198 | 231 |
| M16 | 200 | 289 | 341 |

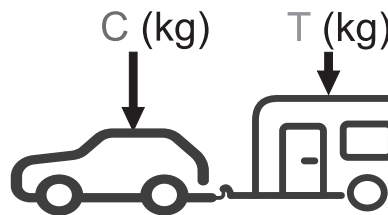

$g = 9,81 \text{ m/s}^2$





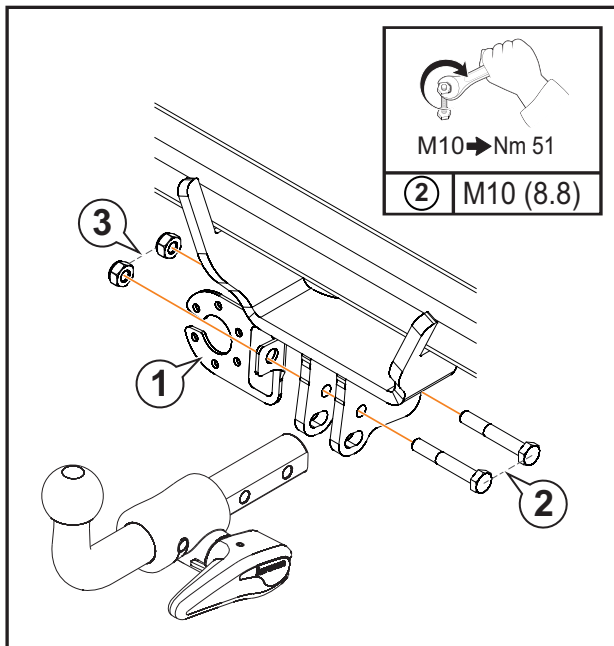
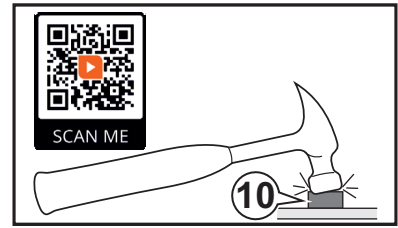
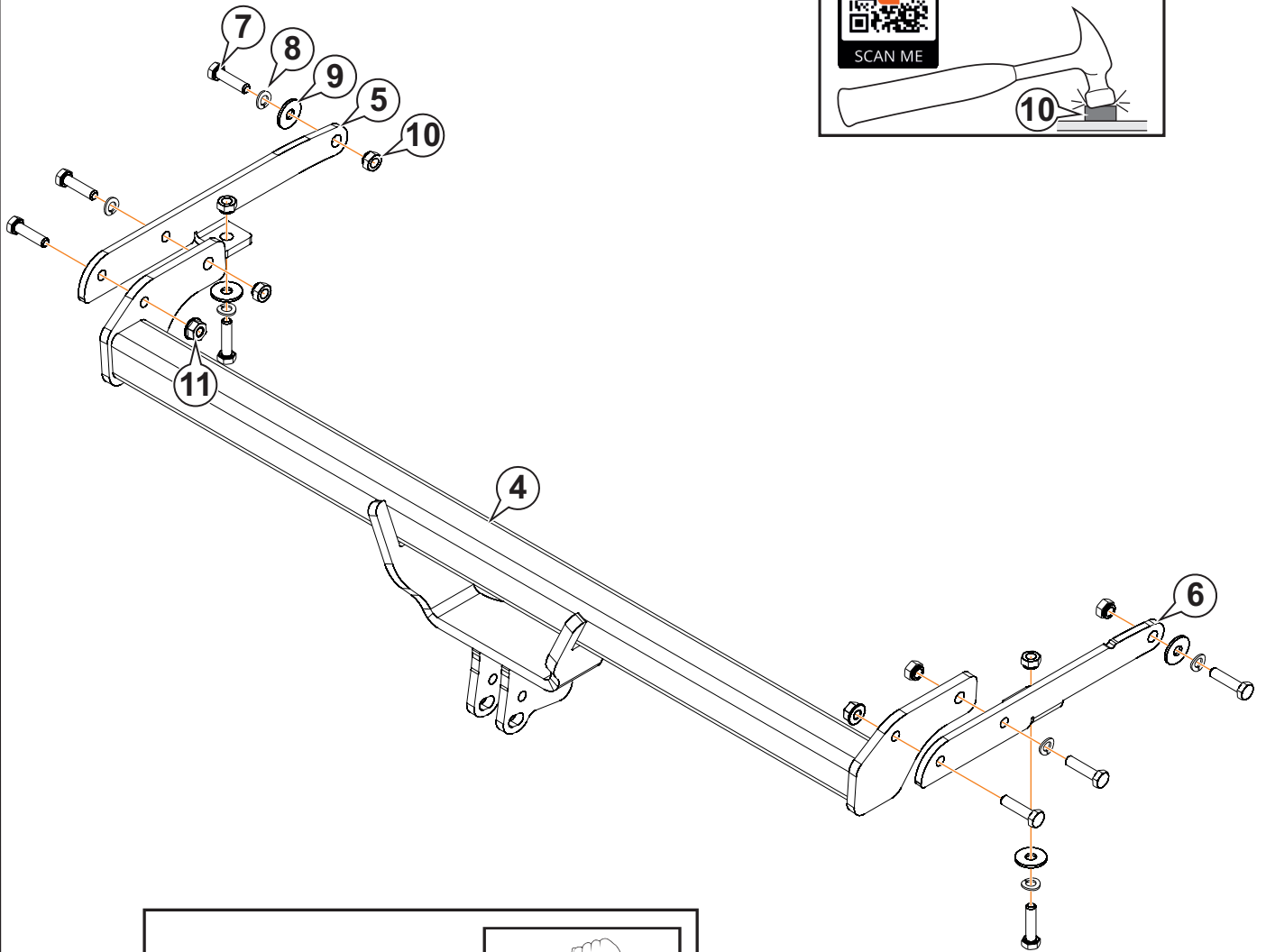

$$D \geq \frac{T \cdot C}{T+C} \cdot \frac{g}{1000} \text{ (kN)}$$

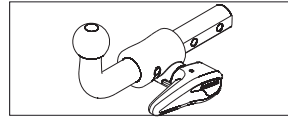
$$T \leq \frac{C \cdot D \cdot 1000}{(C \cdot g) - (1000 \cdot D)} \text{ (kg)}$$

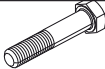
*El MMR (T) puede variar dependiendo del vehículo.

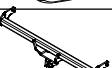
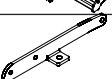
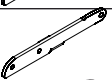
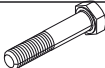



| | | | | |
|----|--|----------------|---|--|
| 1 |  | AEV0005 | 1 | |
| 2 |  | M10x65 DIN 931 | 2 | |
| 3 |  | M10 DIN 980 | 2 | |
| 4 |  | C6107DA60 | 1 | |
| 5 |  | C6107DA24 | 1 | |
| 6 |  | C6107DA25 | 1 | |
| 7 |  | M10x40 DIN 933 | 8 | |
| 8 |  | Ø10 DIN 128A | 6 | |
| 9 |  | Ø10 DIN 9021 | 4 | |
| 10 |  | KALEI M10 | 6 | |
| 11 |  | M10 DIN 6923 | 2 | |

1

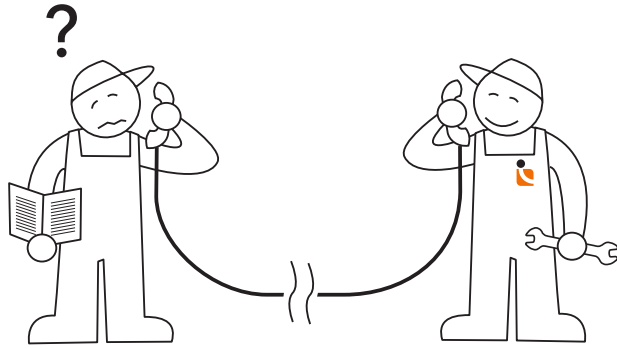

Tel.: (+34) 976 457 130

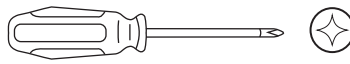
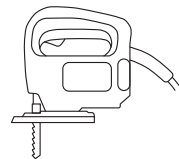
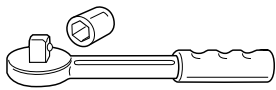

2

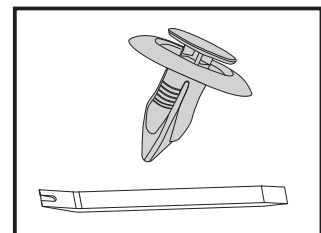
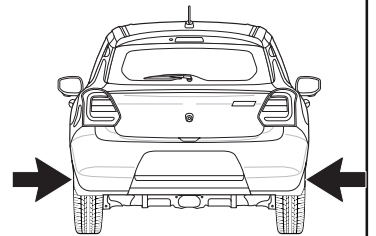
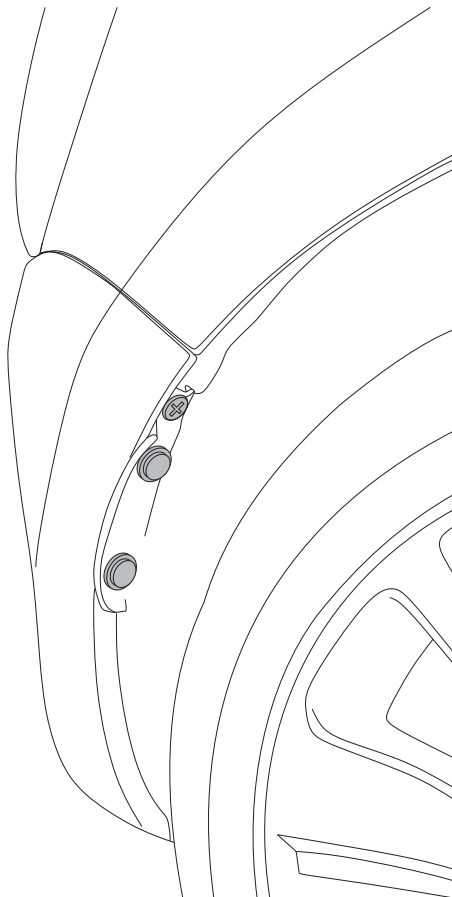
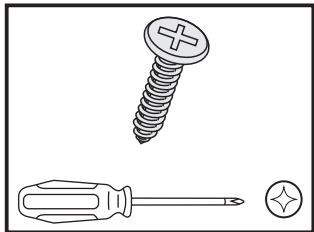

3

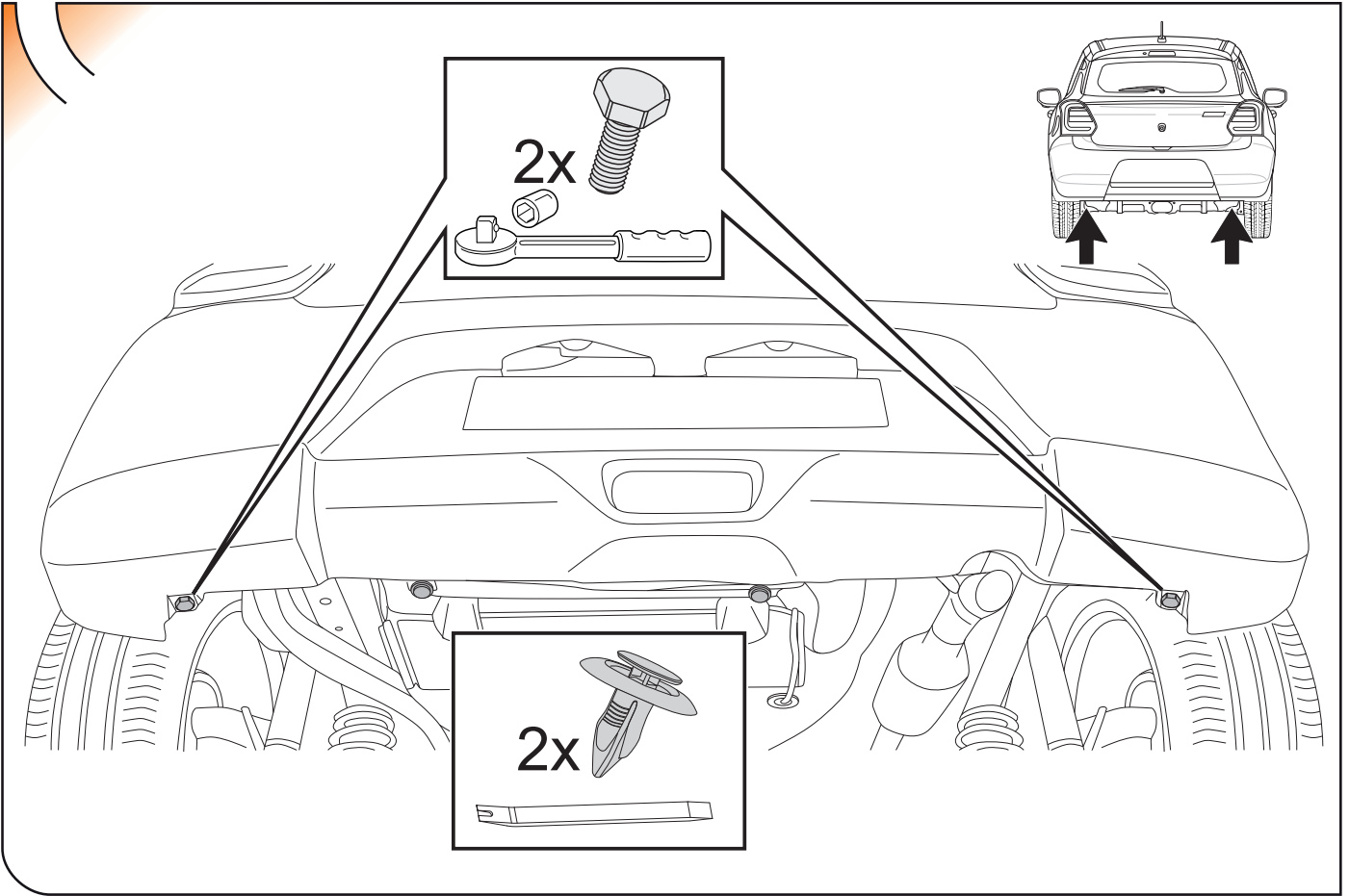

4

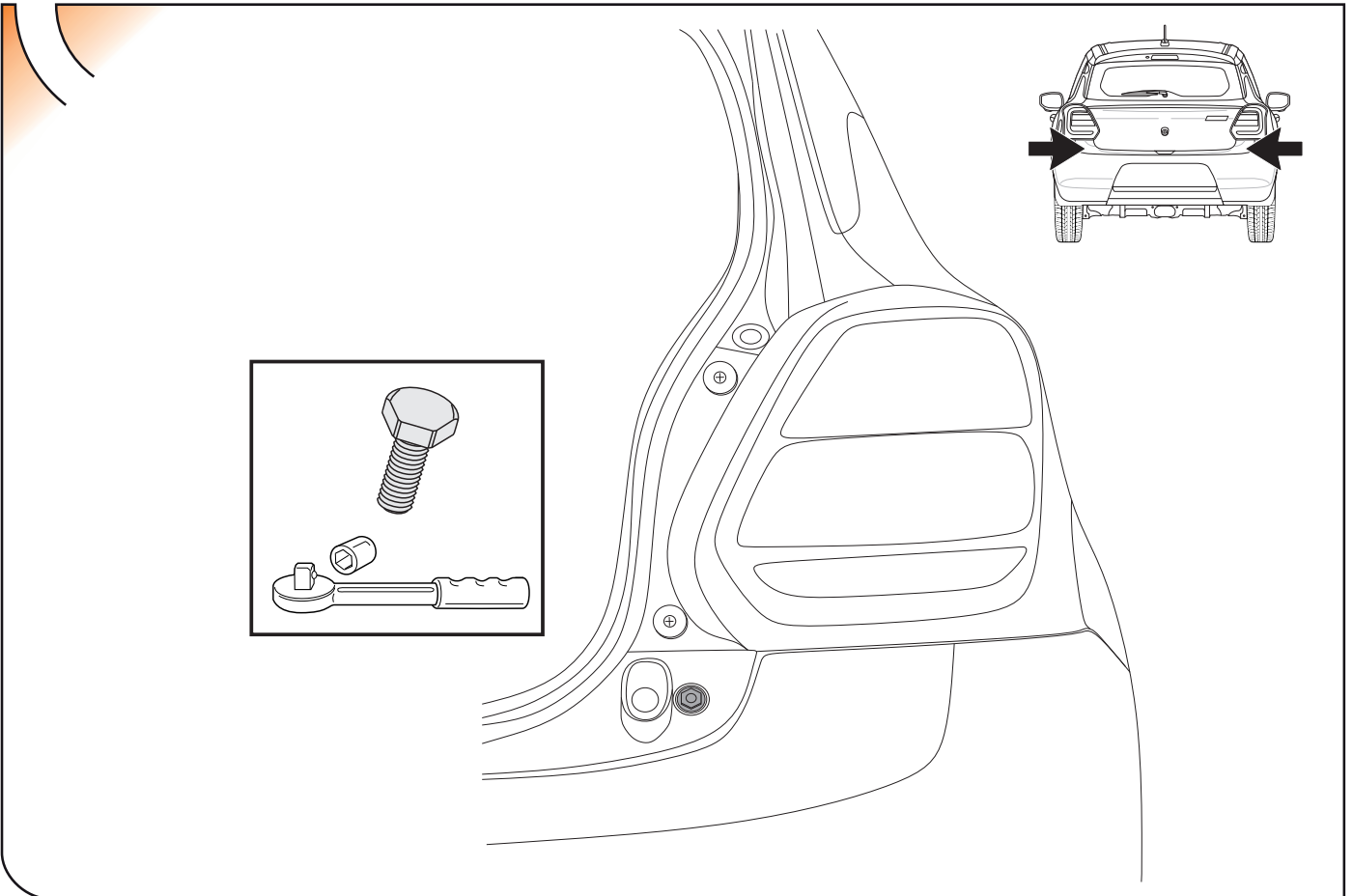

5

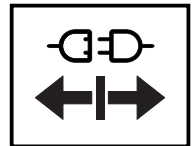
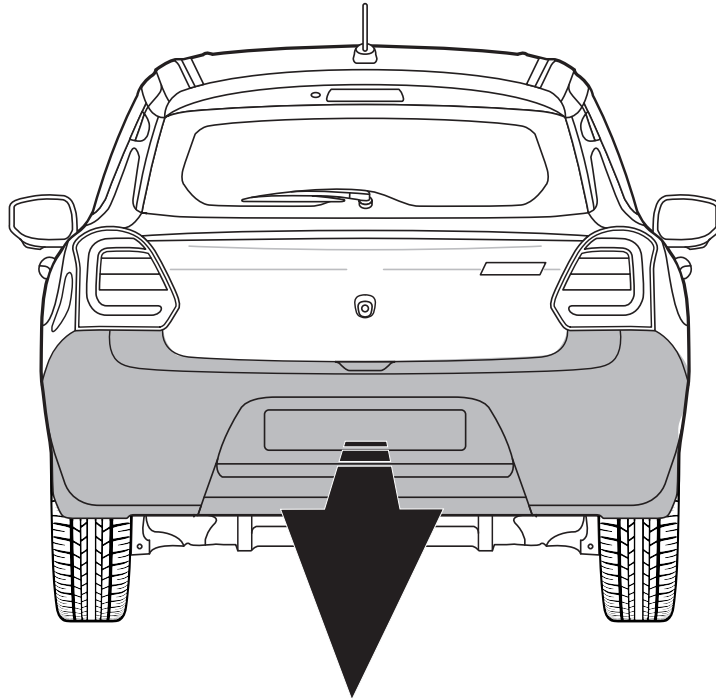

6

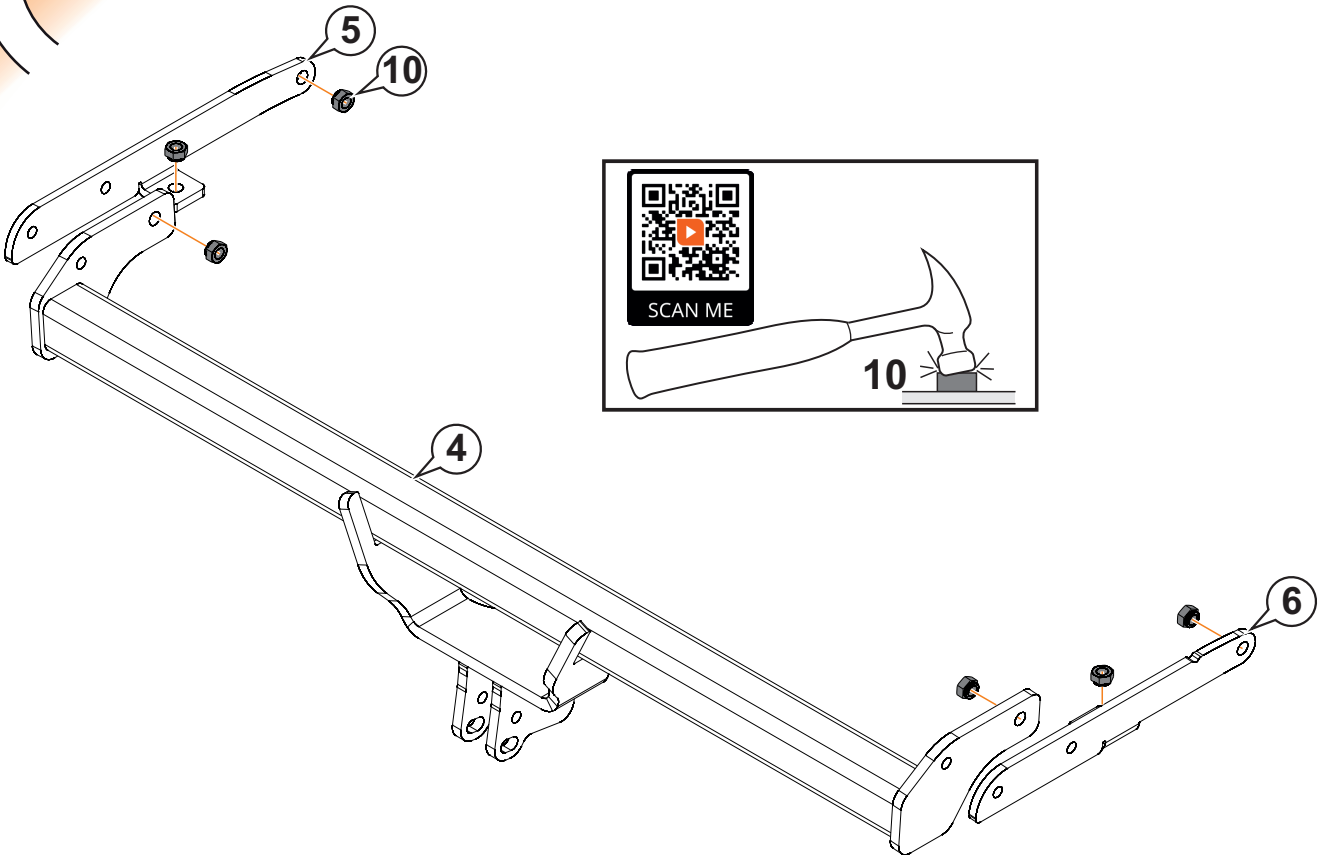

7

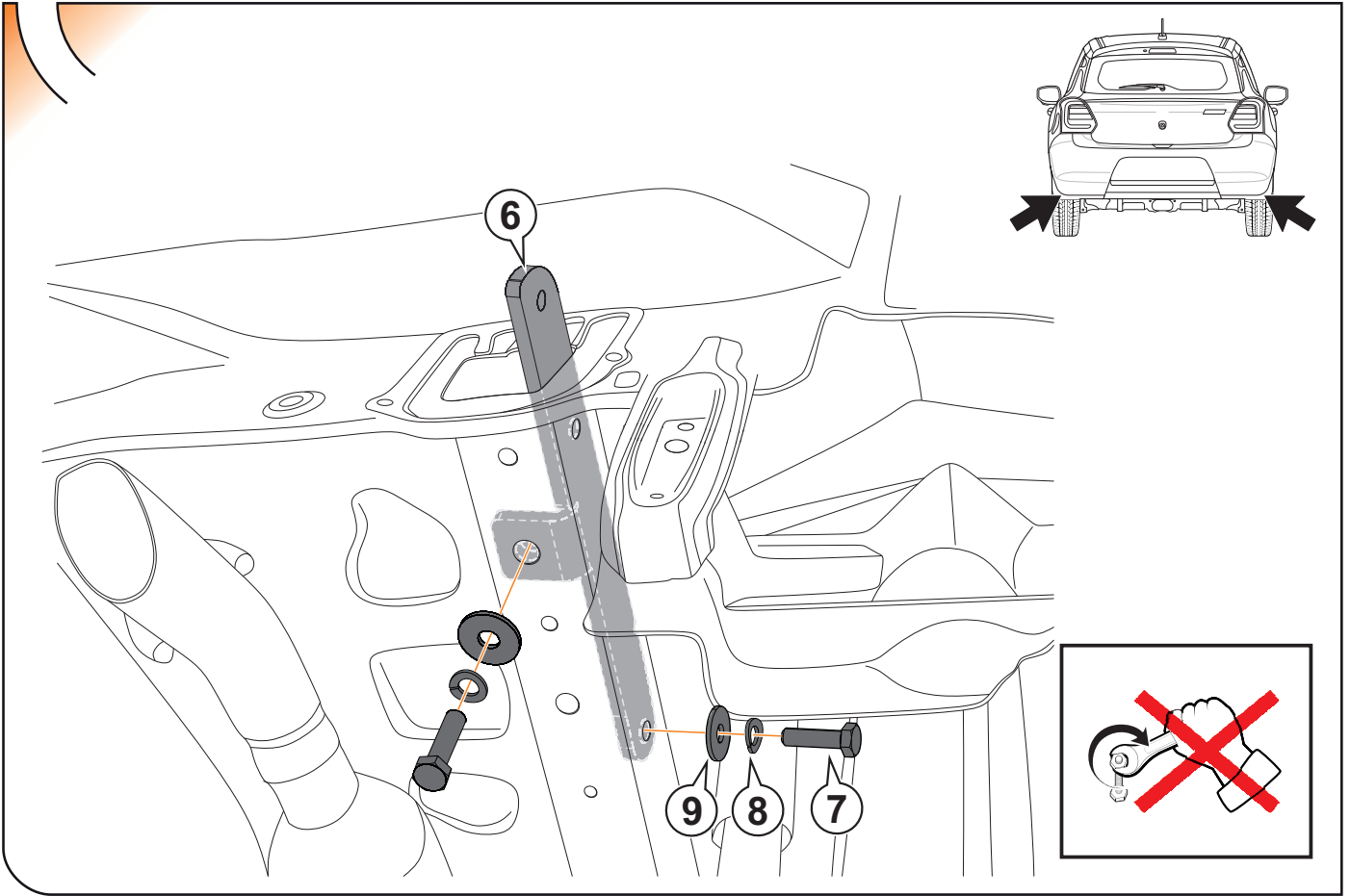

8

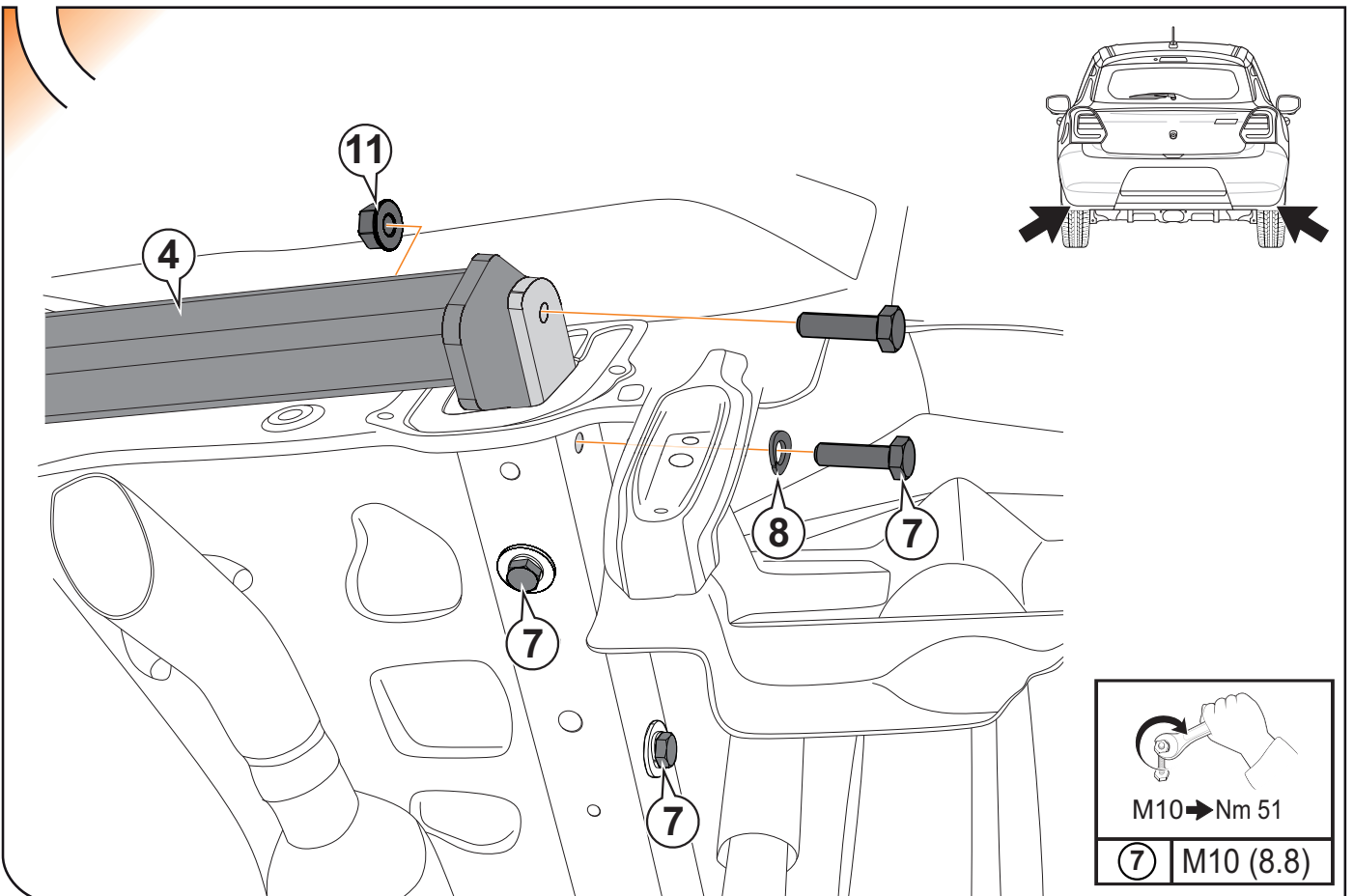

9

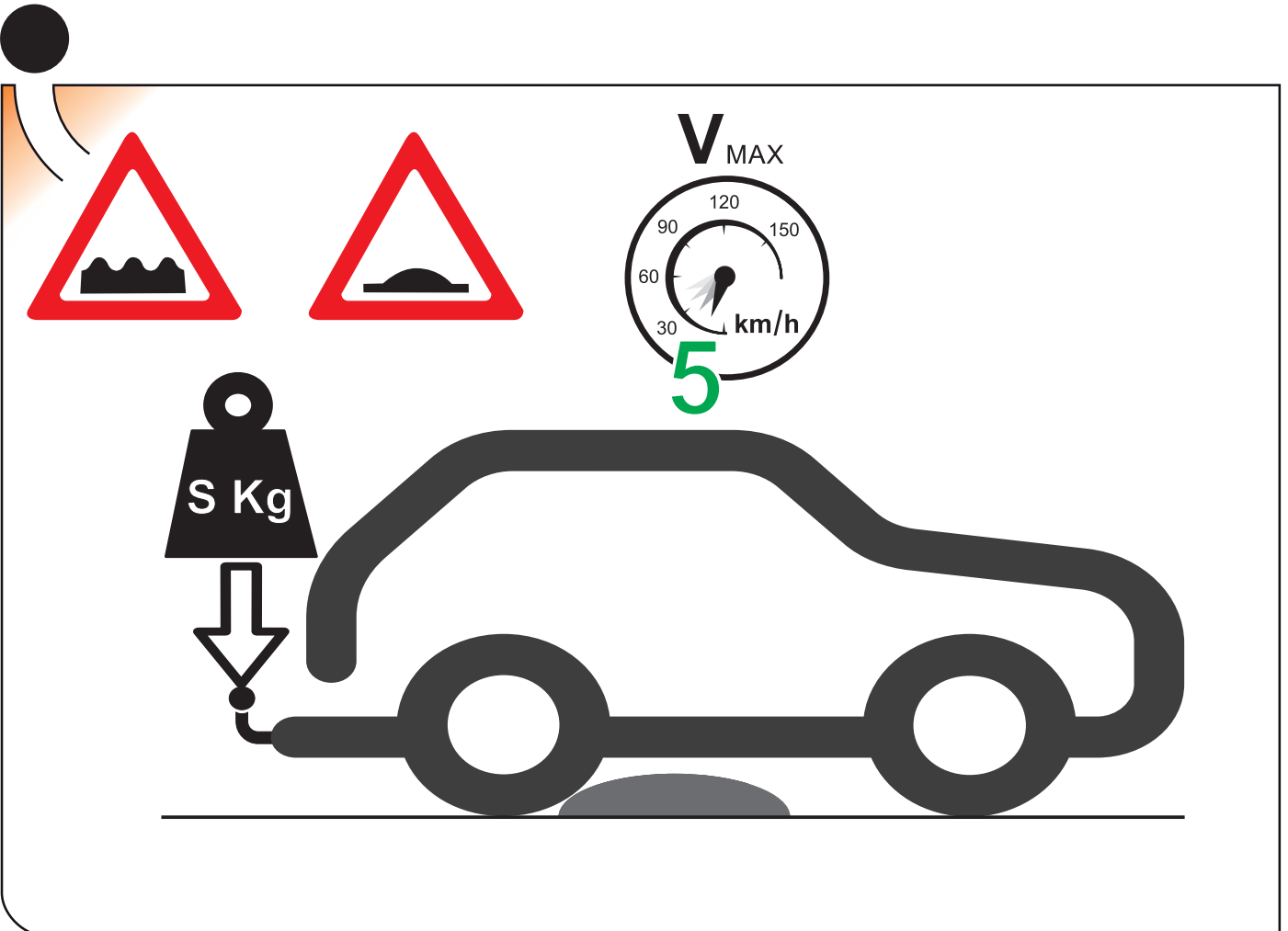
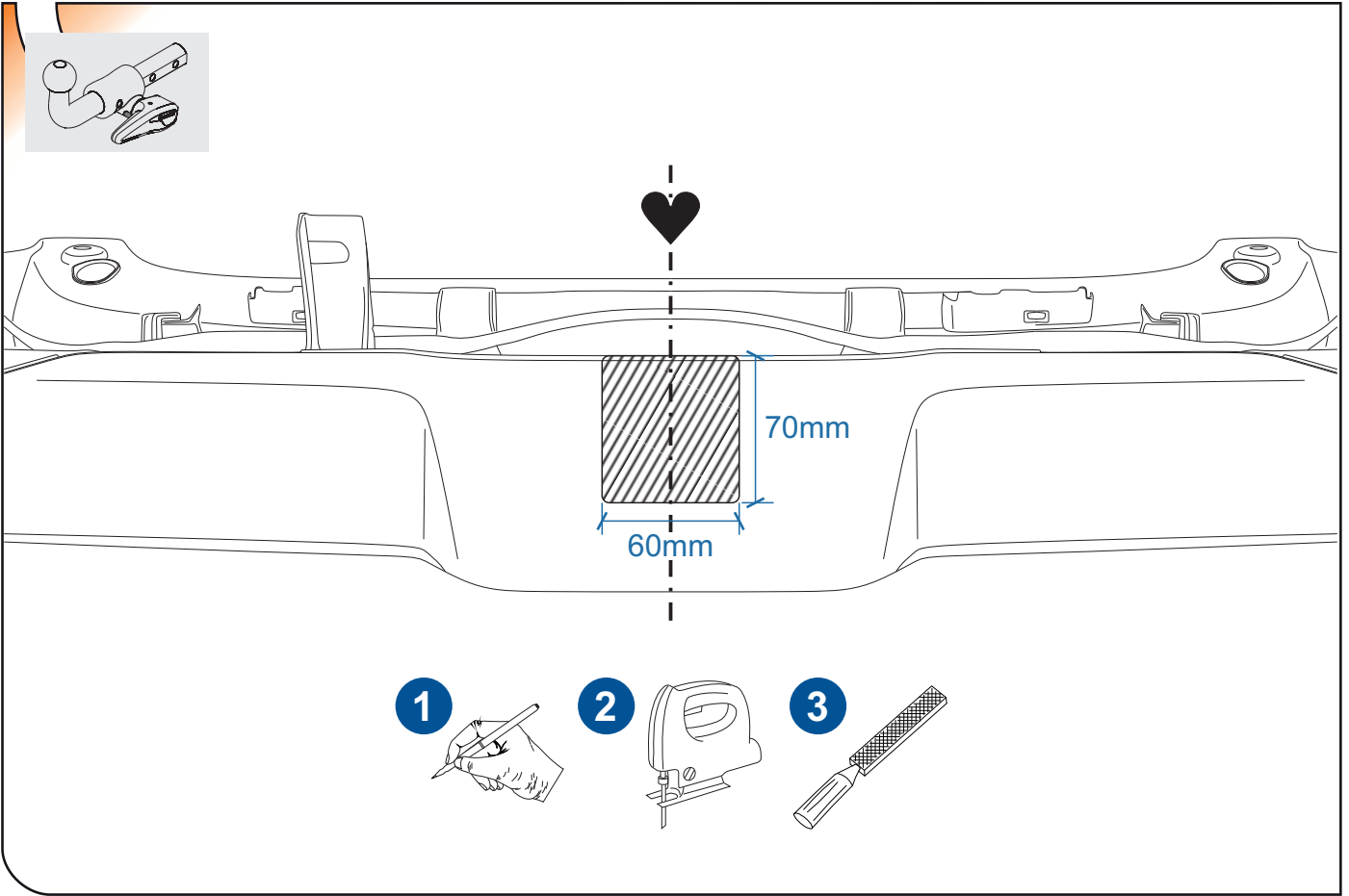

IN

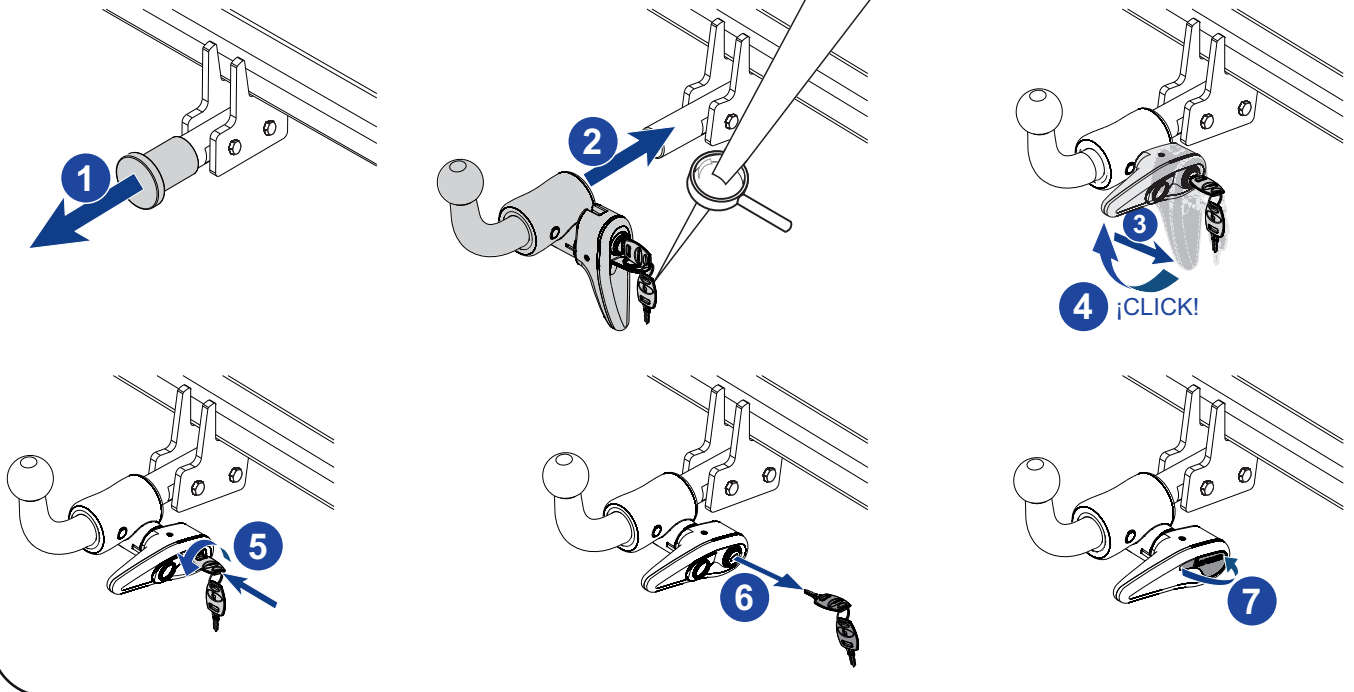
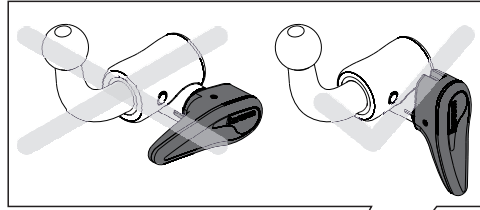

OUT

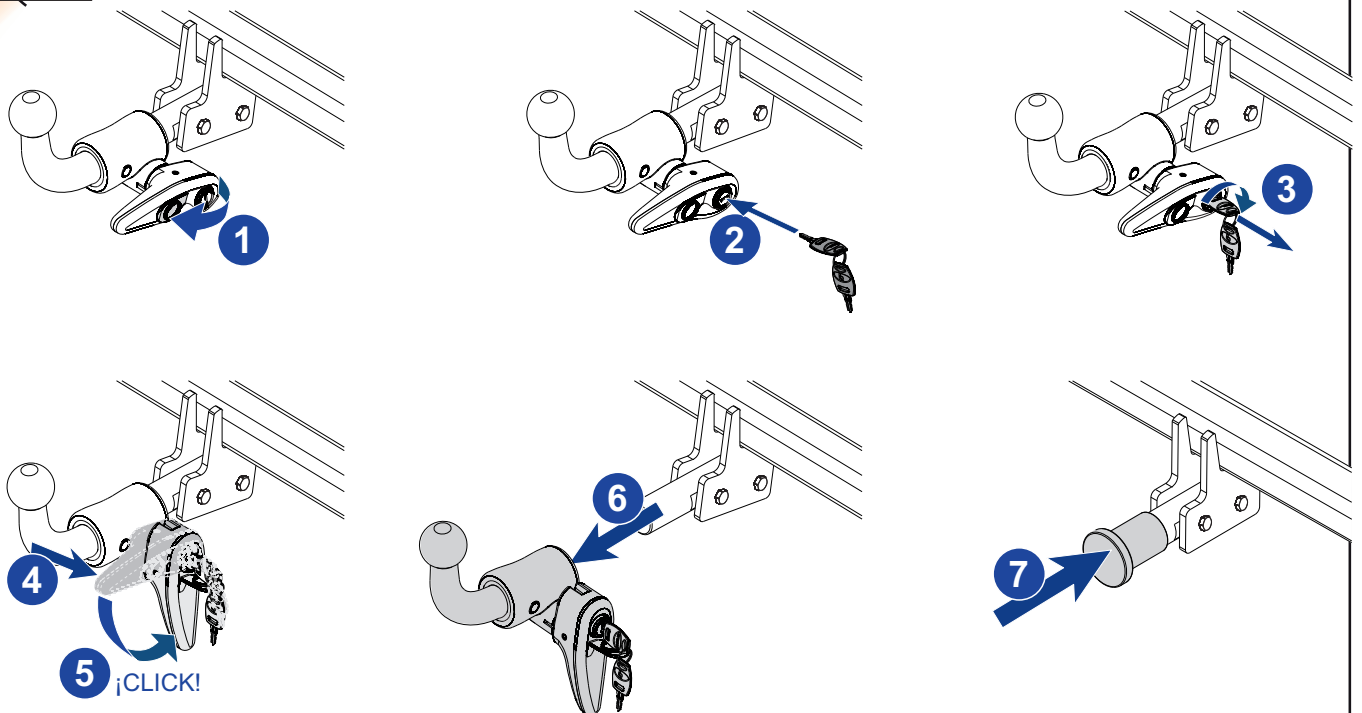



ANEXO III

CERTIFICADO DE TALLER

D. _____, expresamente autorizado por la empresa _____
domiciliada en _____, teléfono _____, dedicada
a la actividad de _____ n° de Registro Industrial _____ y n° de registro
especial (1)_____.

CERTIFICA

Que la mencionada empresa ha realizado la/s Reforma/s y asume la responsabilidad de la ejecución,
sobre el vehículo marca....., tipo.....
variante..... denominación comercial
matrícula y n° de bastidor, de acuerdo con:

- La normativa vigente en materia de reformas de vehículos.
- Las normas del fabricante del vehículo aplicables a la/s reforma/s llevadas a cabo en dicho vehículo.
- El proyecto descriptivo de la/s reforma/s, adjunto al expediente.

OBSERVACIONES: (2)

Tipificada/s con el código de reforma/s.....
Reforma consiste en:

COLOCACION DE ENGANCHE HOMOLOGADO EUROPEO MARCA:

n° de identificación / marca de homologación:

Type :

Garantizo que se cumple lo previsto en el artículo 6 del Reglamento General de vehículos y, en su caso, en el artículo 9 del R.D. 1457/1986, de 10 de enero, por el que se regula la actividad industrial en talleres de vehículos automóviles, de equipos y sus componentes, modificado por 455/2010 de 16 de abril.

....., a.....de.....de

Firma y sello:

(1) En el caso de que la reforma sea efectuada por el fabricante se indicará N/A.

(2) Se debe especificar en este apartado OBSERVACIONES, la identificación de los equipos o sistemas modificados.

ES

1

ANEXO III
CERTIFICADO DE TALLER



2



3



IT

1

DICHIARAZIONE DI CORRETTO MONTAGGIO

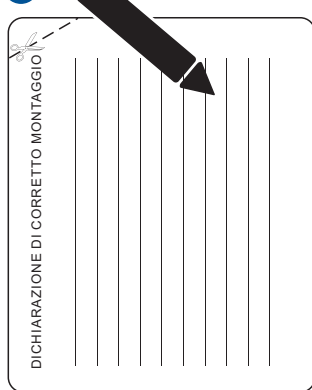

2

