

**Peugeot E-3008 (2024- )**

**Peugeot 3008 (2024- )**

**Peugeot 5008 (2024- )**

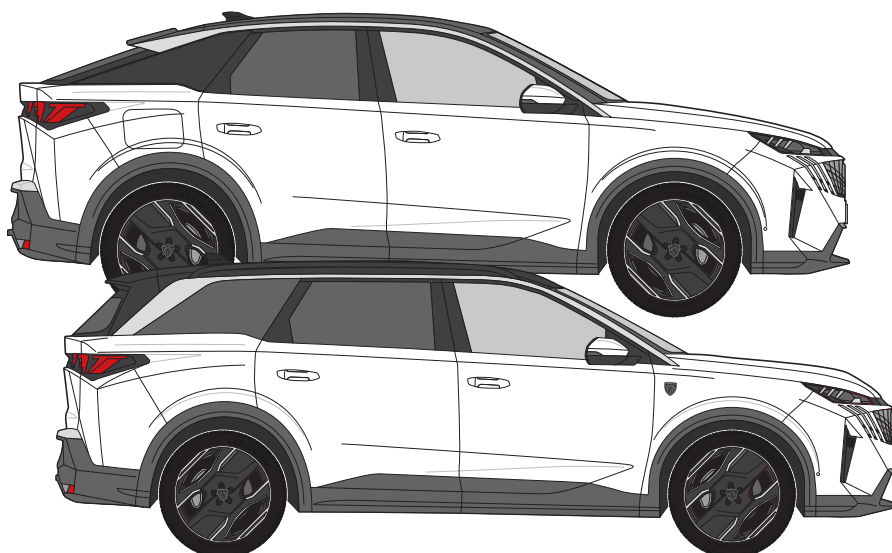



Peugeot E-3008 (2024- )  
 Peugeot 3008 (2024- )  
 Peugeot 5008 (2024- )

**R55**

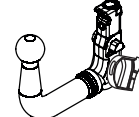
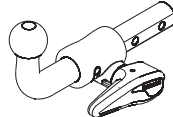
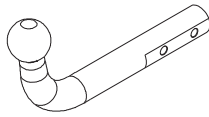

**TowCar** enganches **aragon**

**E<sub>9</sub>** APPROVALNUMBER: 55R-02 2891 D-VALUE: D 10,9 kN

TYPE: PEU058 CLASS: A50-X MAX.VERT.LOAD: S 133 kg

**TowCar** enganches **aragon**

**E<sub>9</sub>** APPROVALNUMBER: 55R-02 2891 D-VALUE: D 10,9 kN

TYPE: PEU058 CLASS: A50-X MAX.VERT.LOAD: S 133 kg

**TowCar** enganches **aragon**

**E<sub>9</sub>** APPROVALNUMBER: 55R-02 2892 D-VALUE: D 10,9 kN

TYPE: PEU059 CLASS: A50-X MAX.VERT.LOAD: S 133 kg

D = 10,9 kN



S = 133 kg

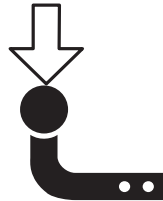

\*T = 1760 Kg

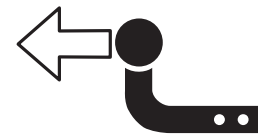

N/m	8,8	10,9	12,9
M6	10	15	18
M8	24	36	42
M10	51	75	87
M12	87	130	147
M14	138	198	231
M16	200	289	341

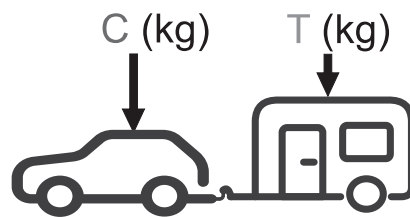









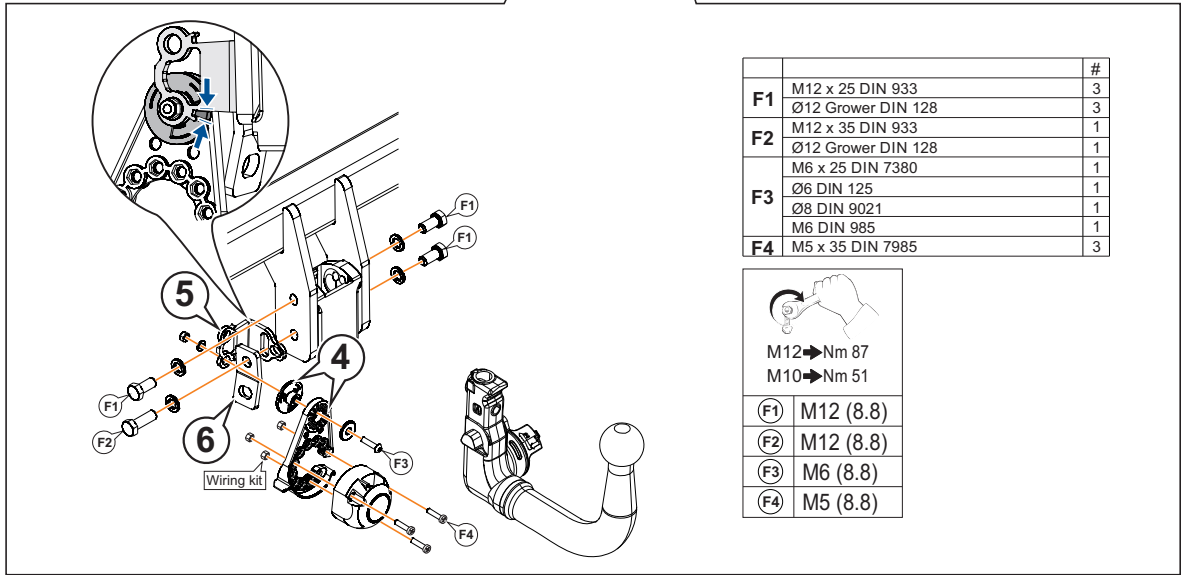
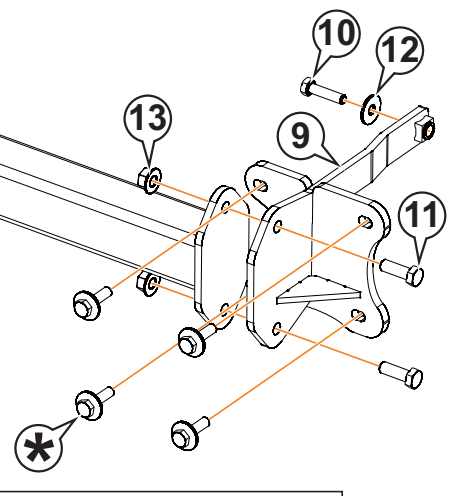
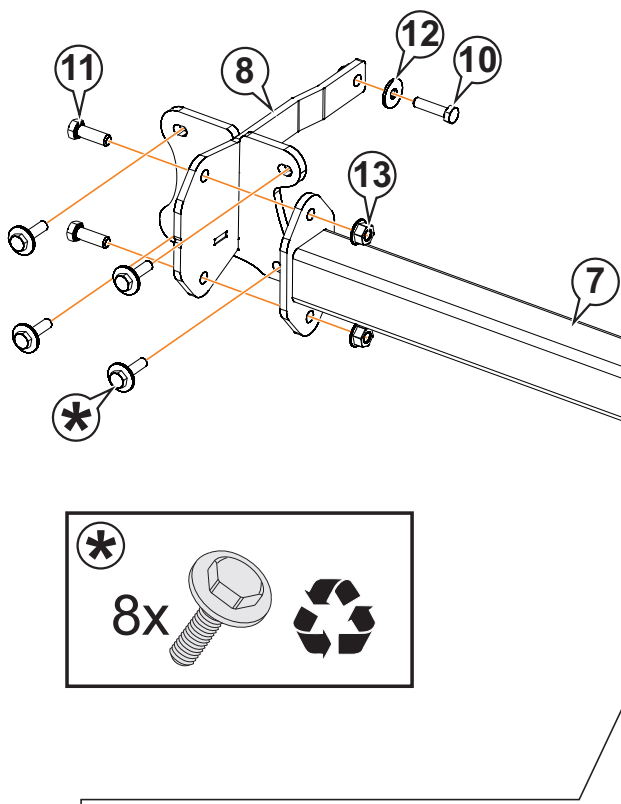
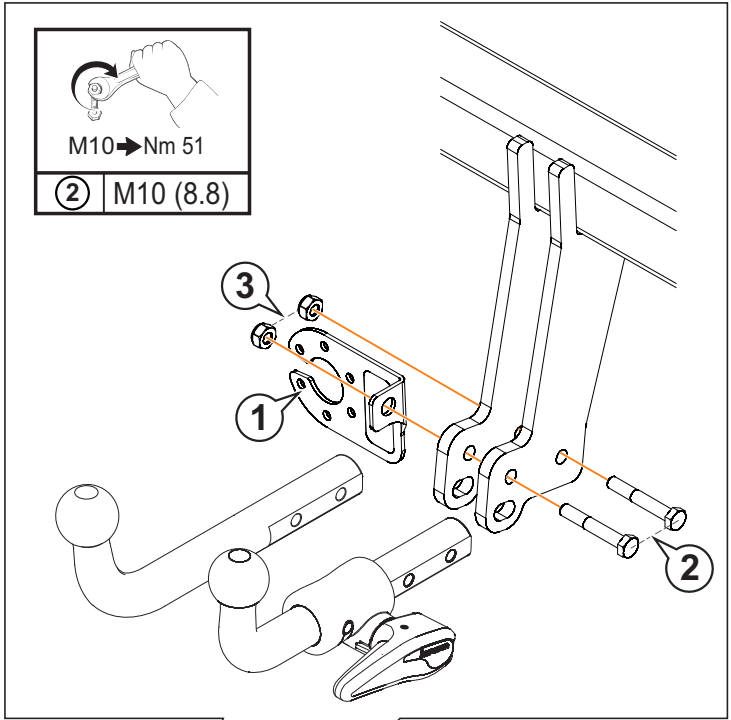

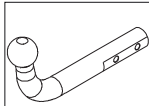
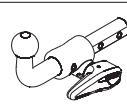
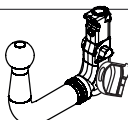
$g = 9,81 \text{ m/s}^2$

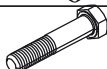
$$D \geq \frac{T \cdot C}{T + C} \cdot \frac{g}{1000} \text{ (kN)}$$

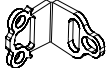
$$T \leq \frac{C \cdot D \cdot 1000}{(C \cdot g) - (1000 \cdot D)} \text{ (kg)}$$

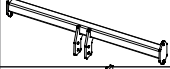
\*El MMR (T) puede variar dependiendo del vehículo.

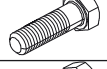
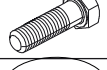

					
1		AEV0005	1		
2		M10x65 DIN 931 (8.8)	2		
3		M10 DIN 980	2		
4		AEV0073			1
5		AEV0072			1
6		AEV0006			1
7		C4723FX60	1		1
8		C4723FV62	1		1
9		C4723FV61	1		1
10		M10x40 DIN 933 (8.8)	2		2
11		M12x35 DIN 933 (8.8)	4		4
12		Ø10 DIN 9021	2		2
13		M12 DIN 6923	4		4

1



5 min.

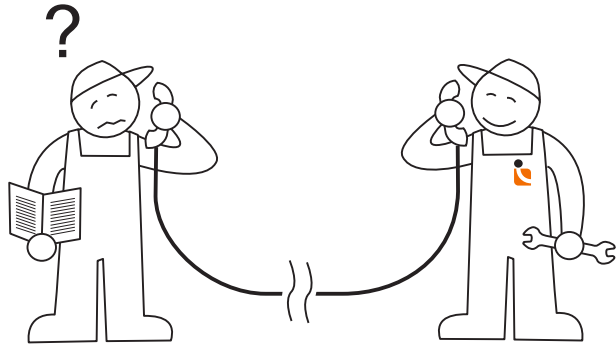

Tel.: (+34) 976 457 130

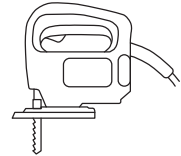
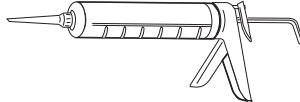
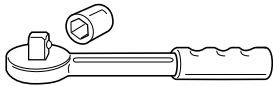

2

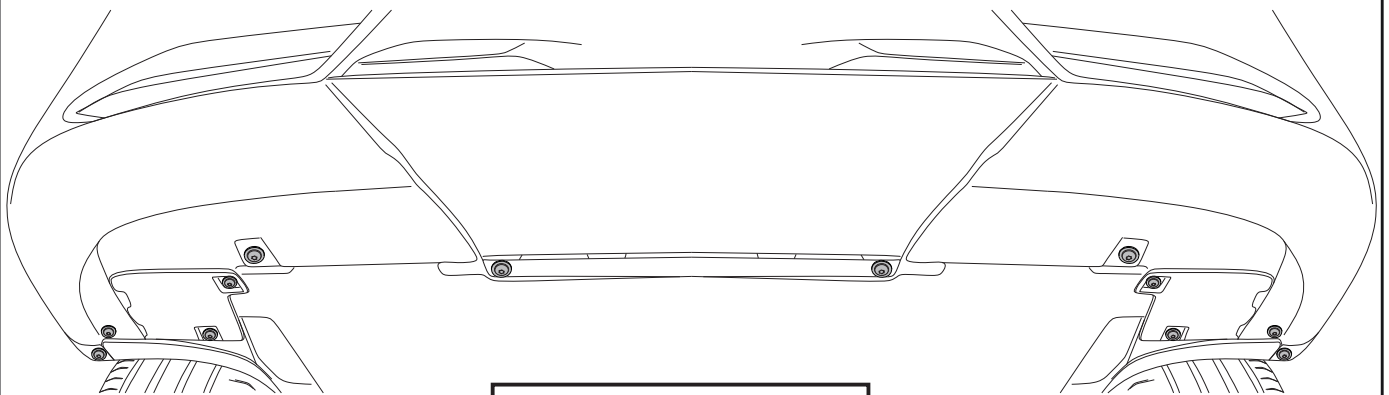
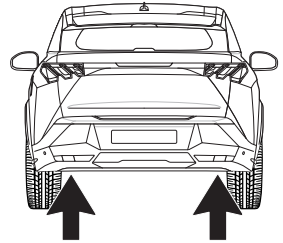

12x

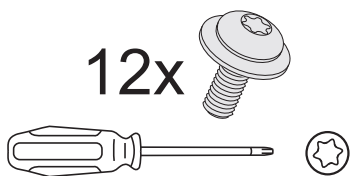

3

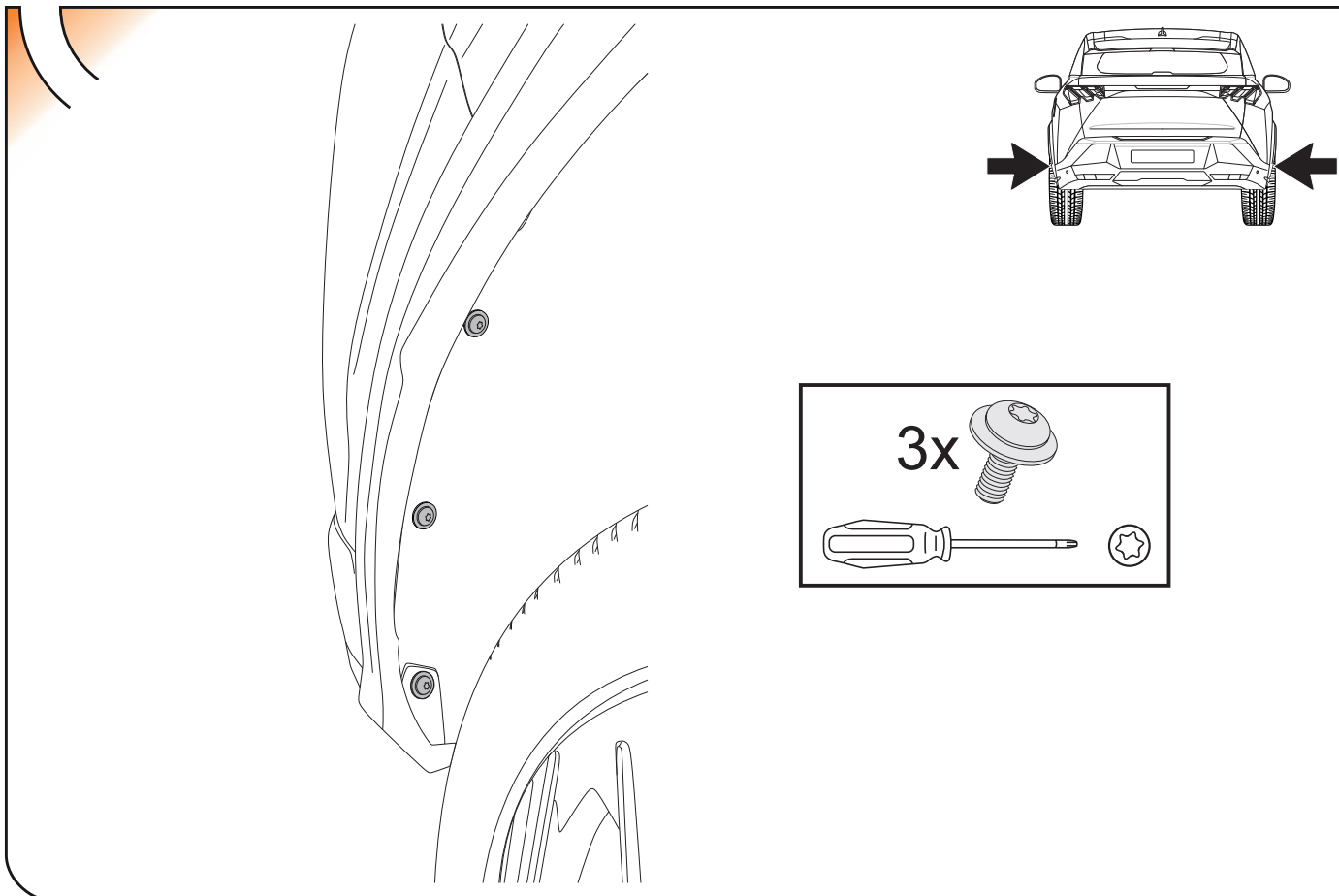

4

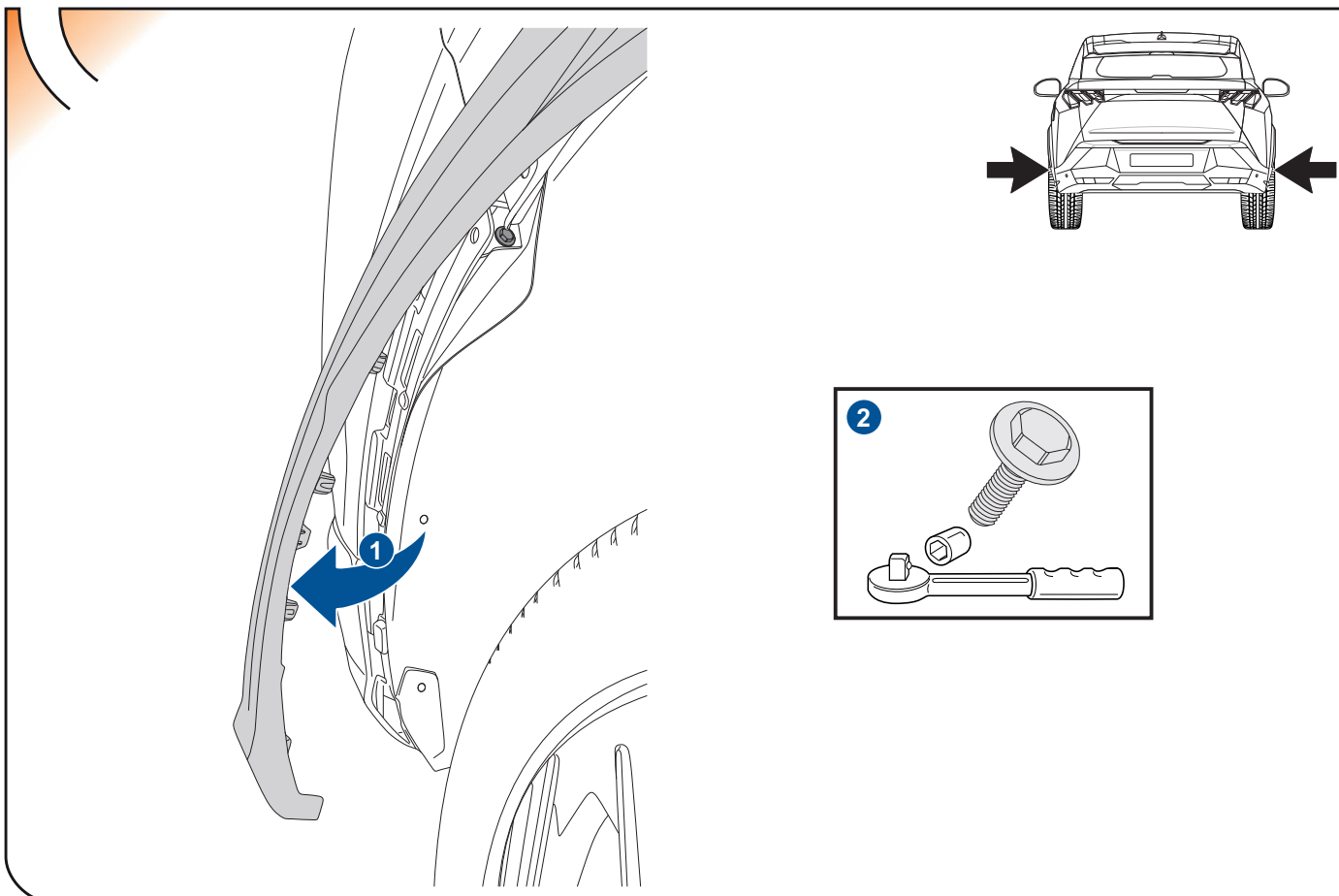

5

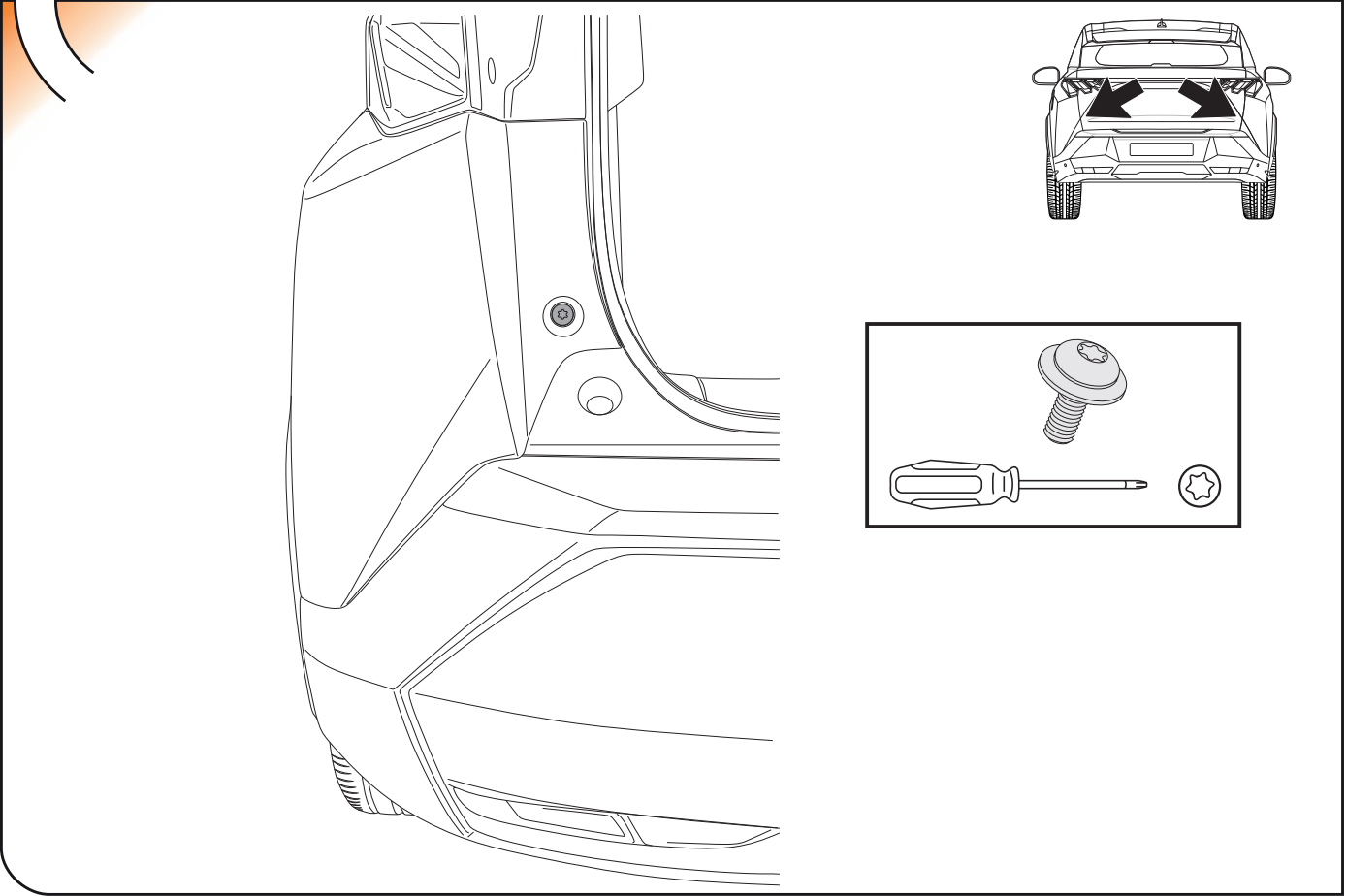

6

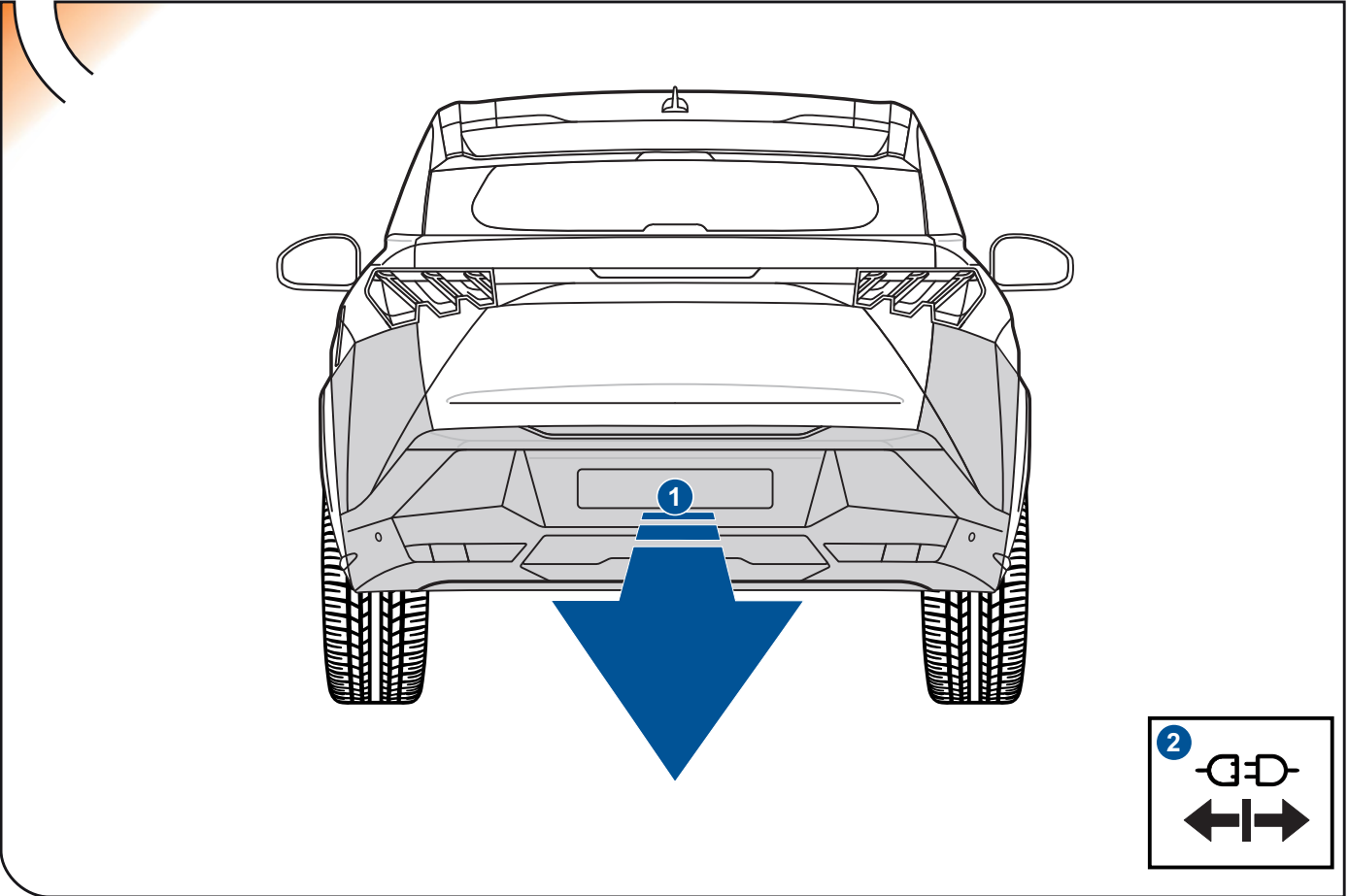



7

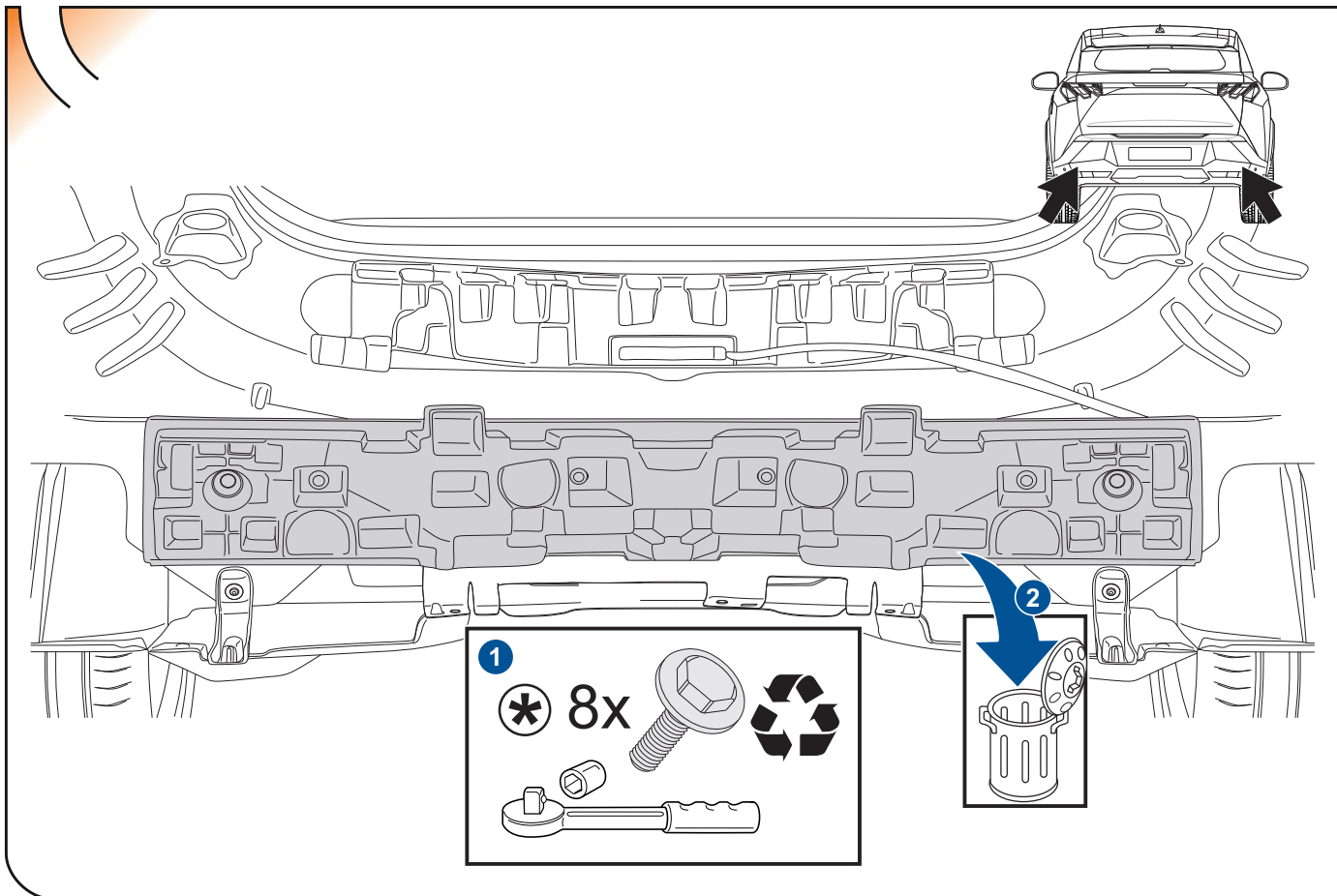

8

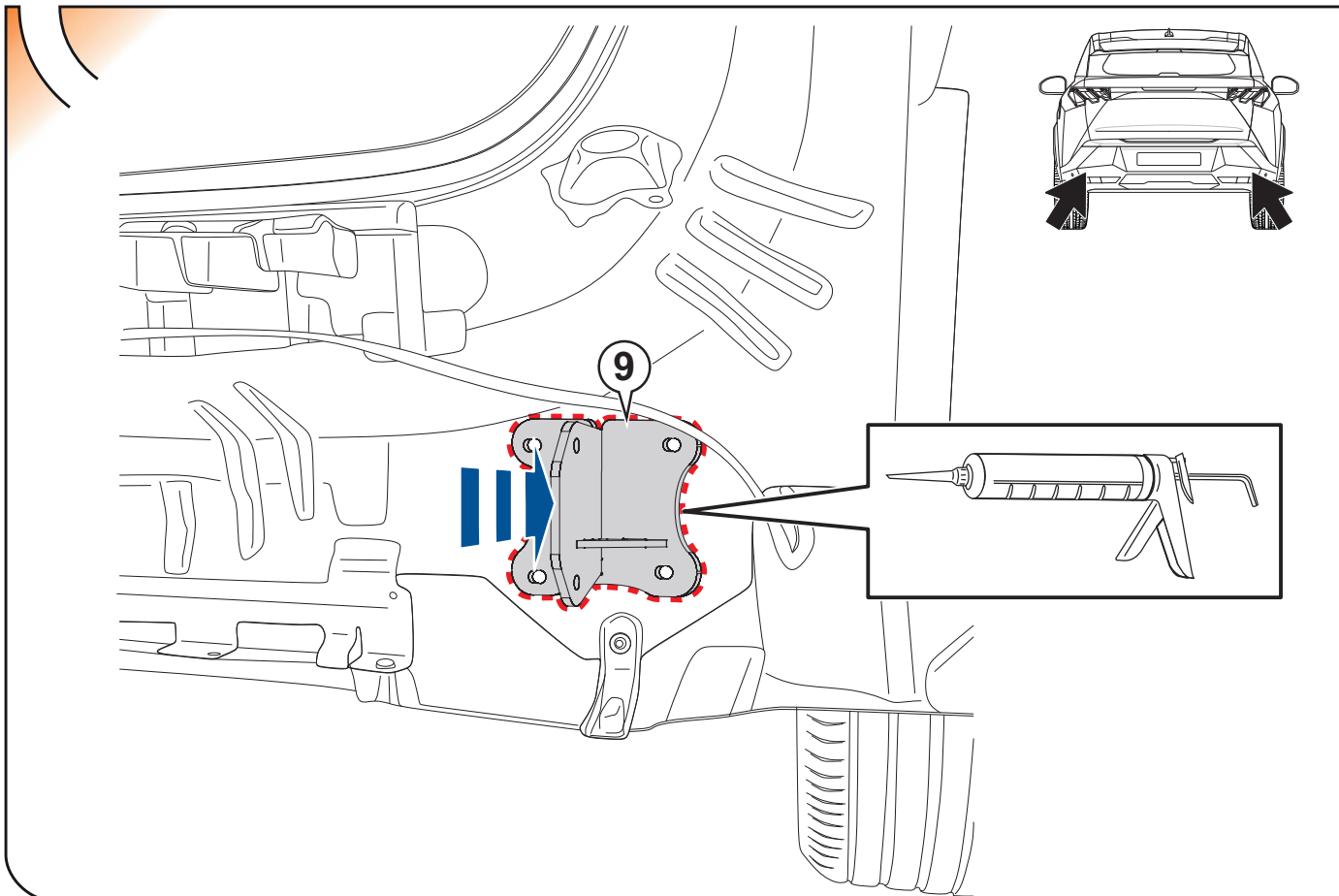

9

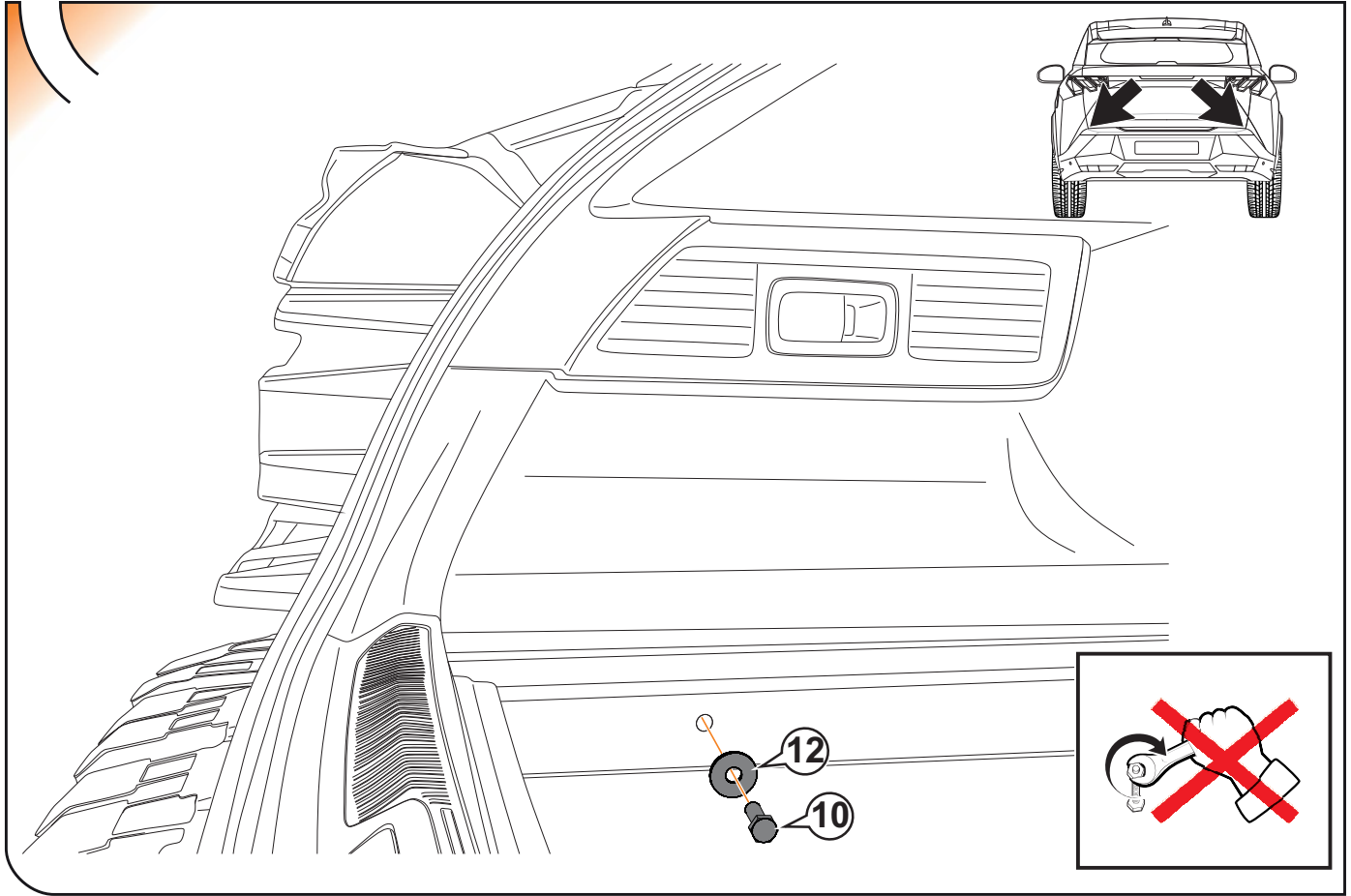

10

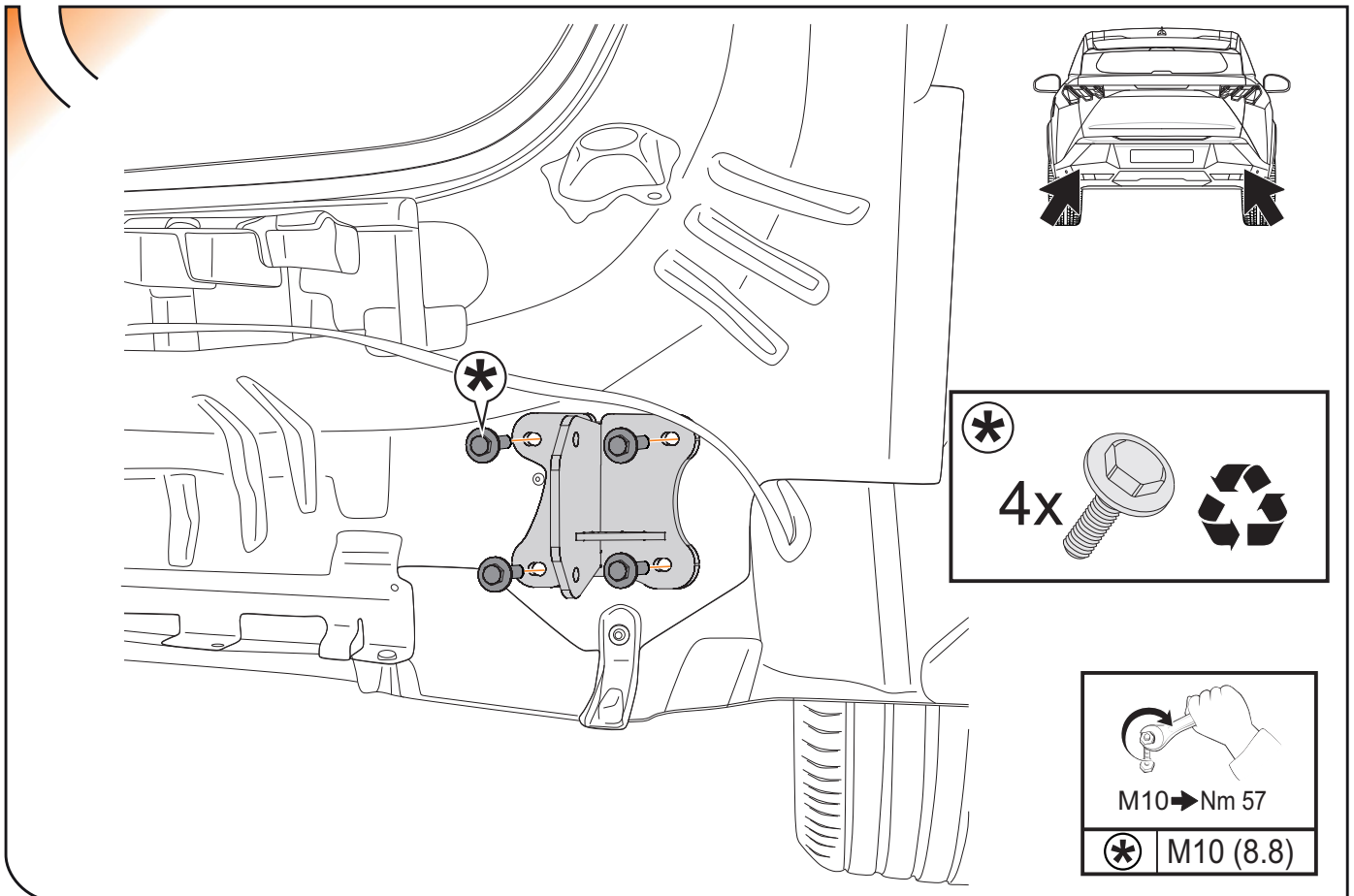

11

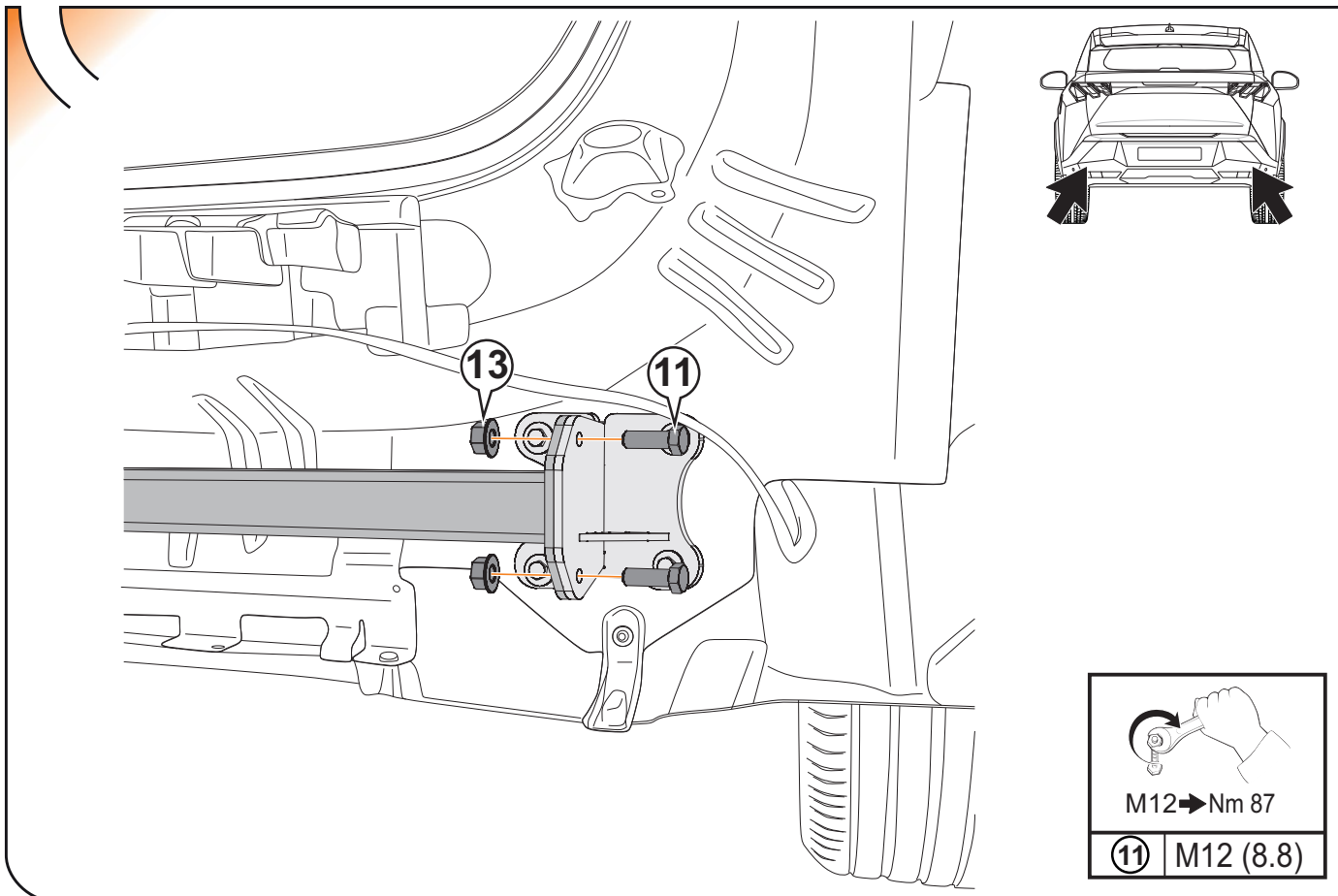

12

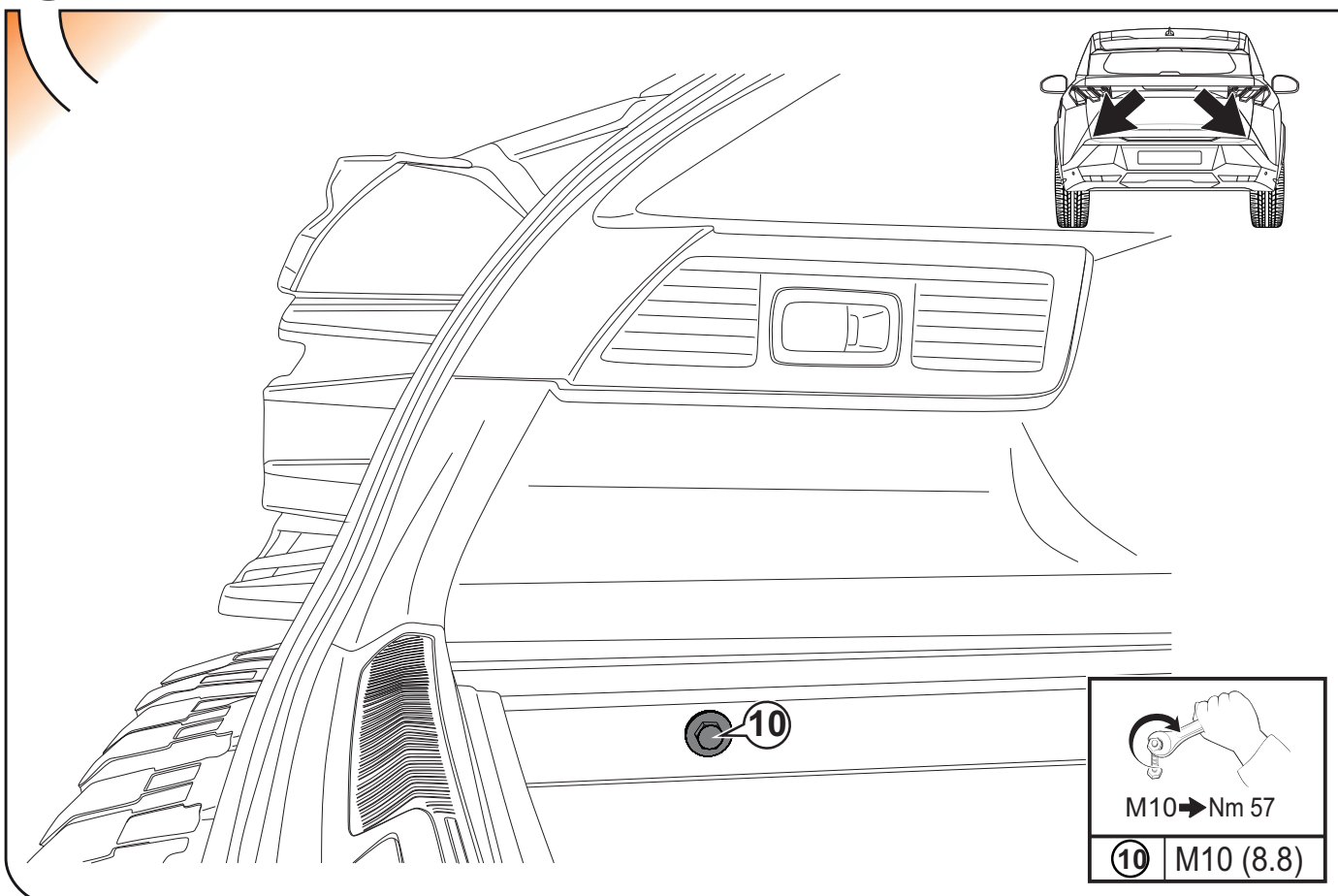

13

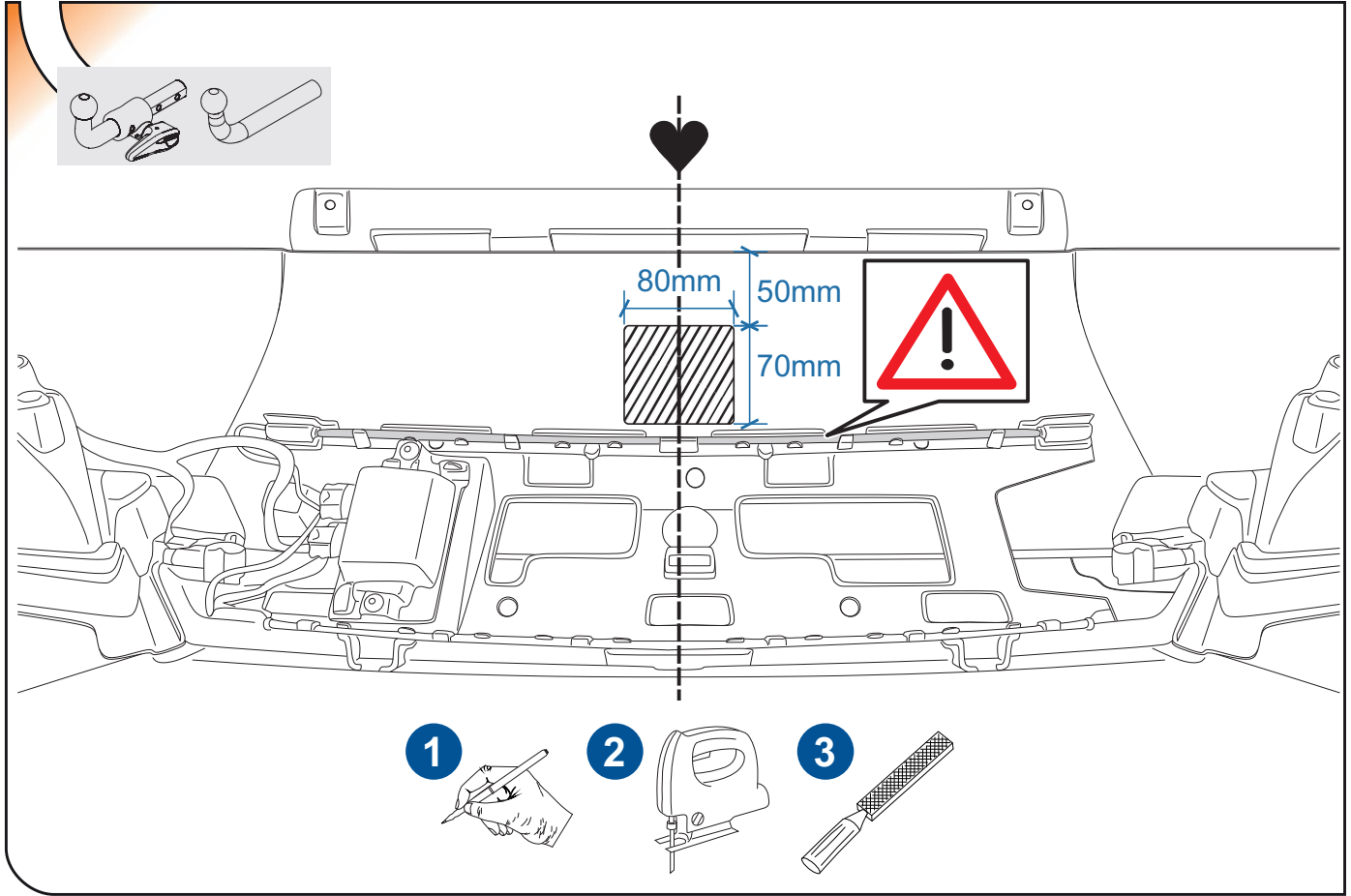

14

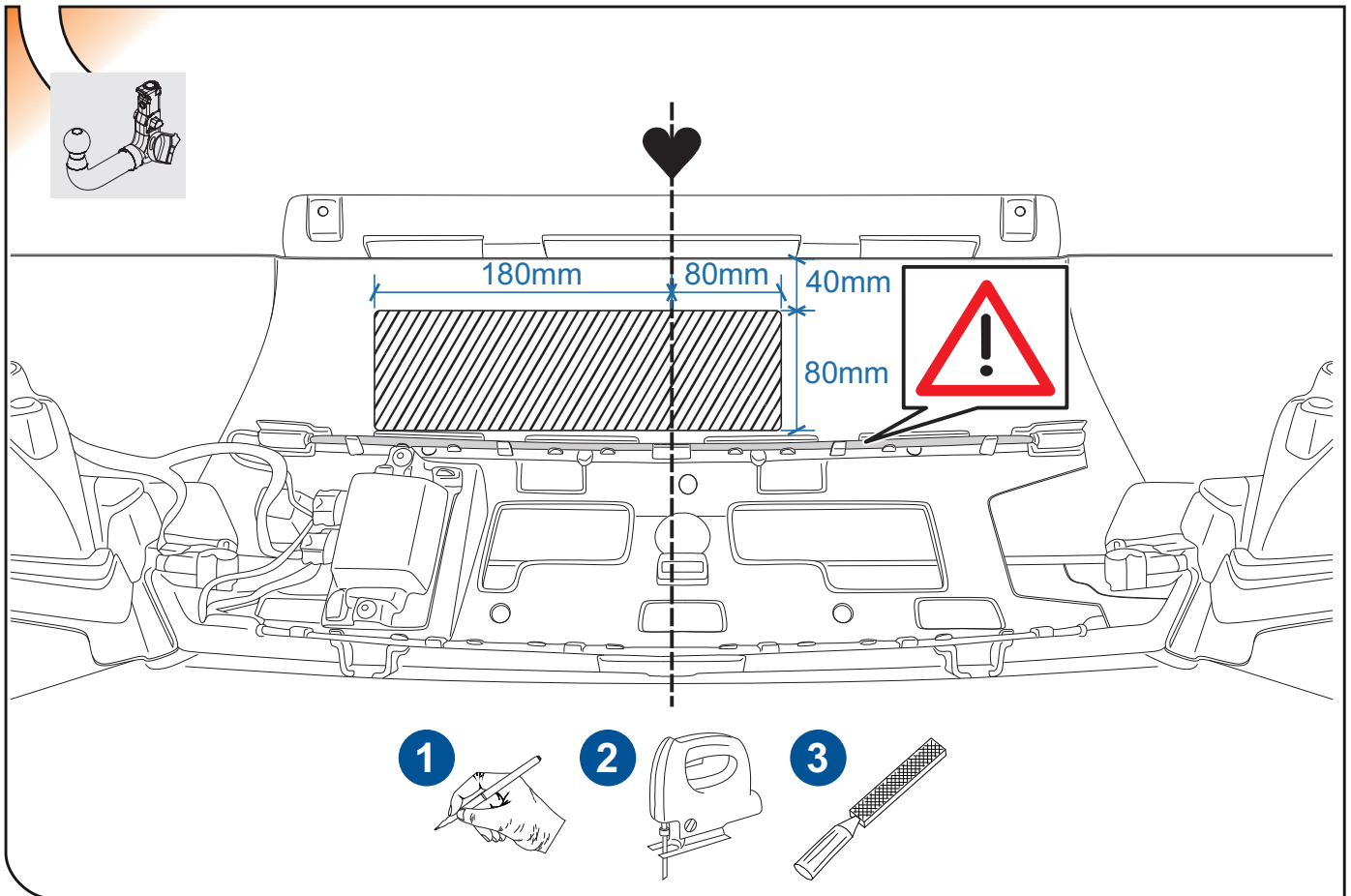

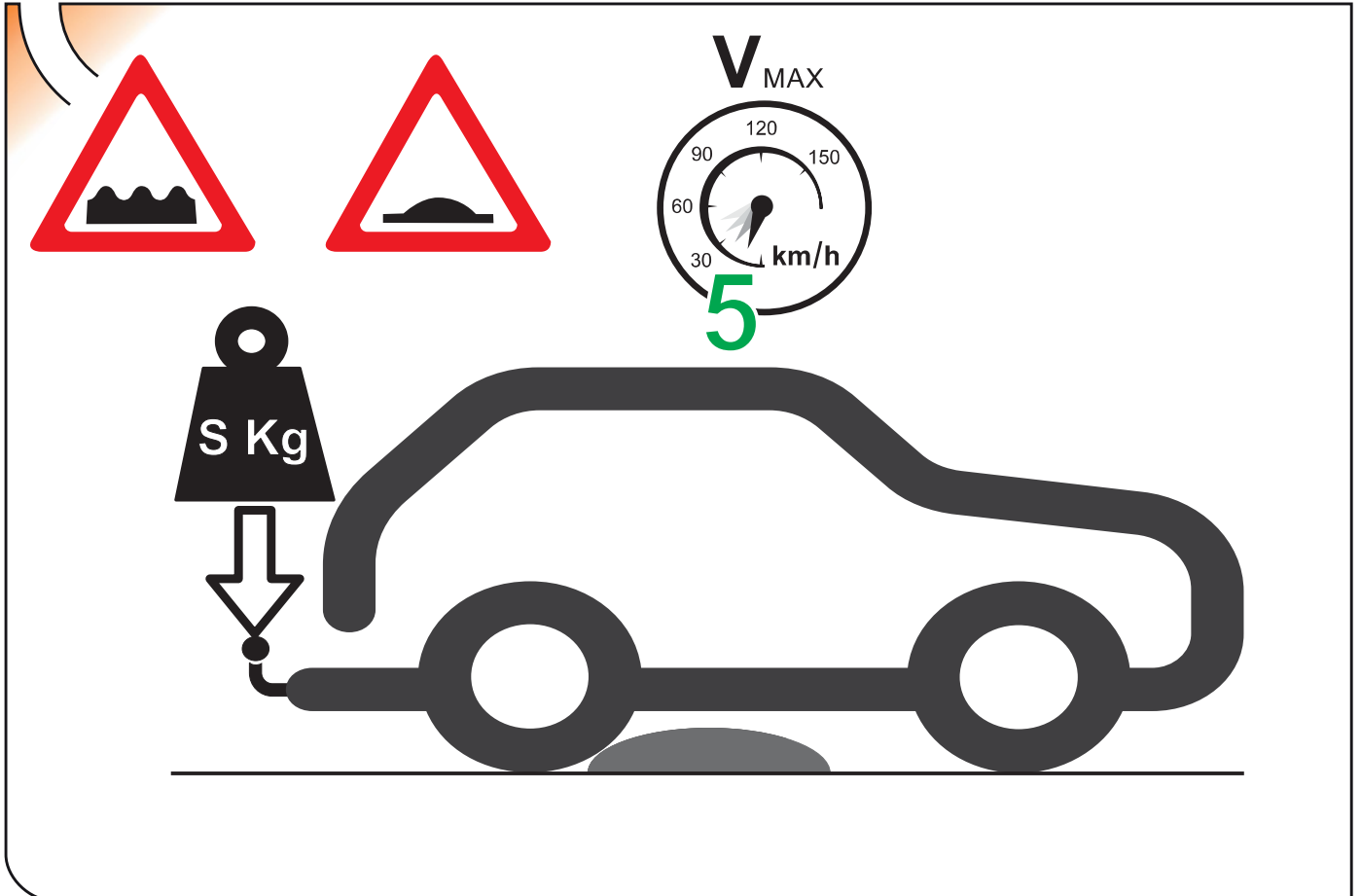
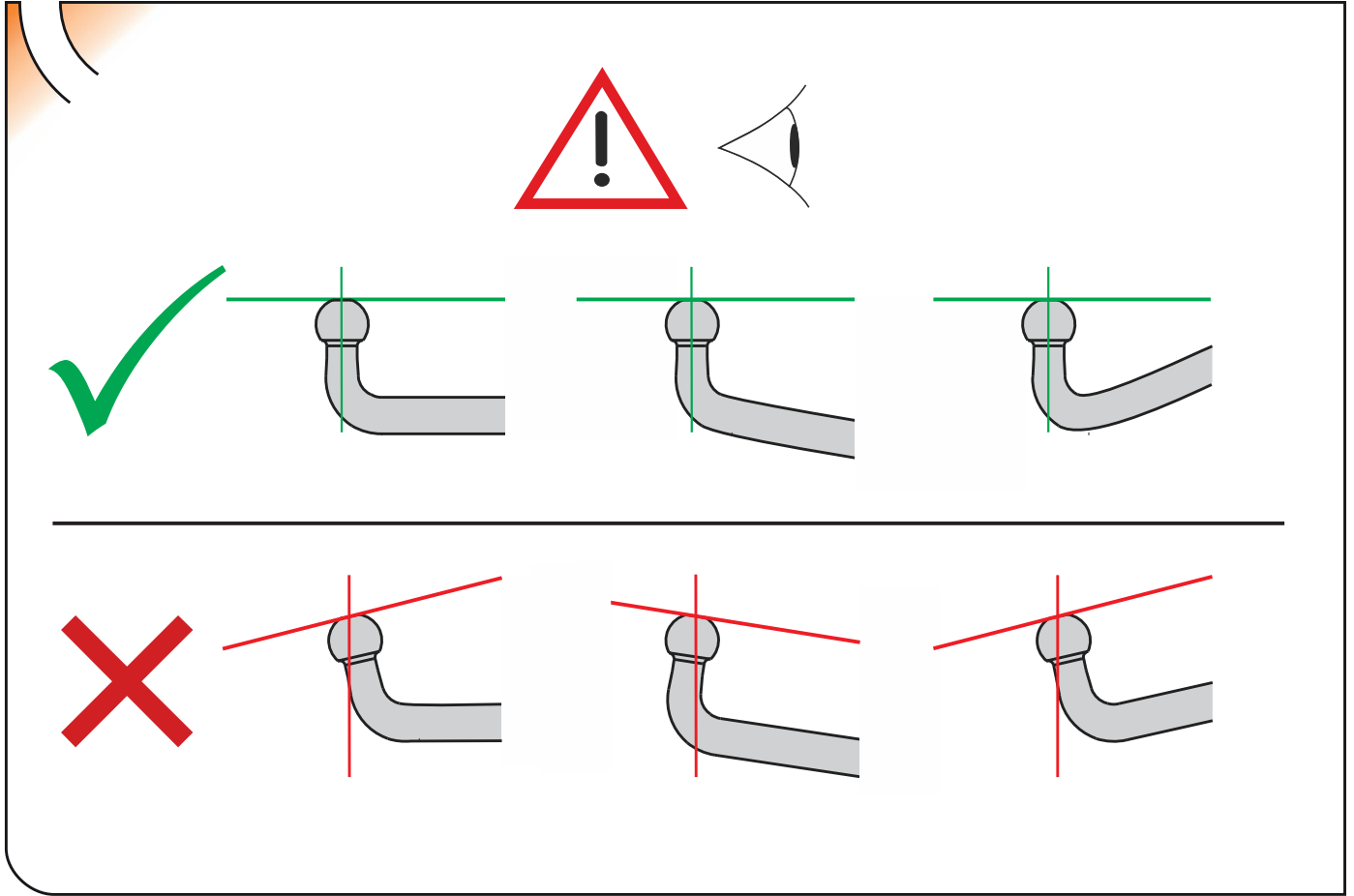

**IN**

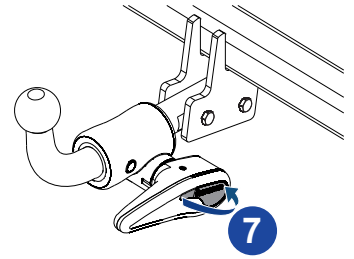
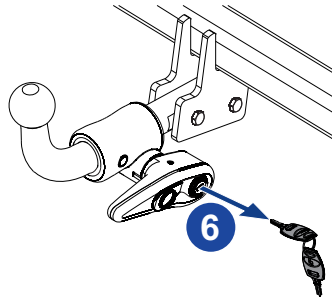
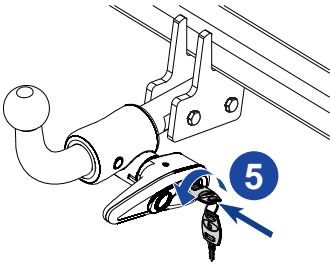
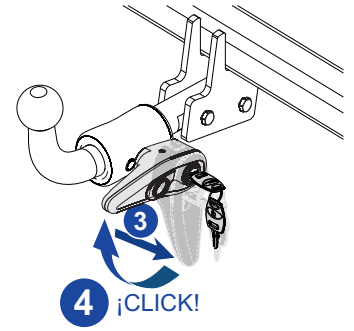
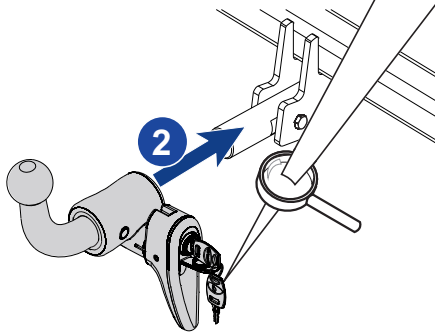
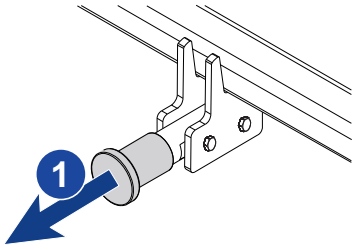
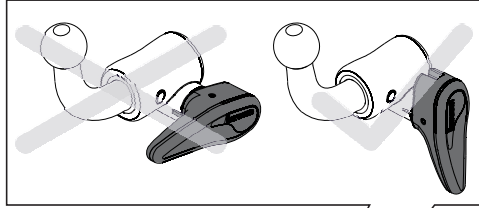

**OUT**

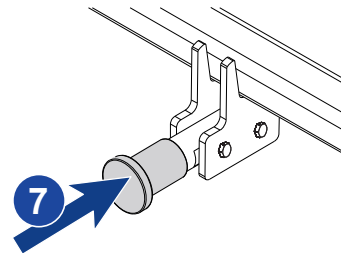
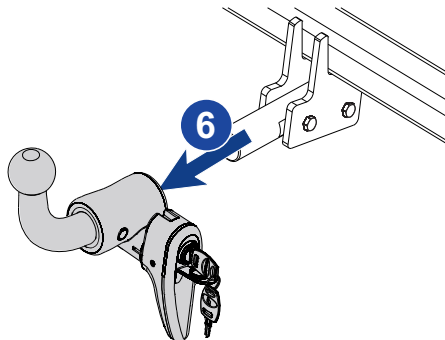
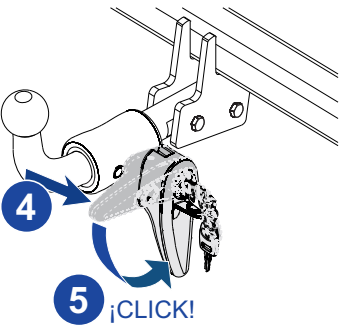
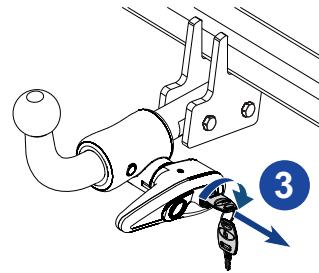
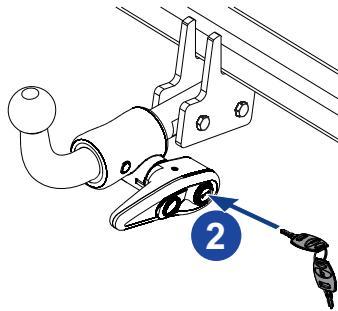
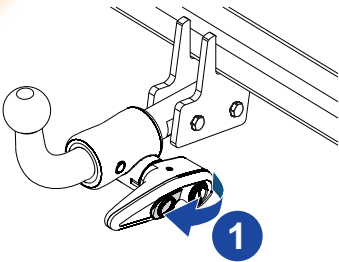

**IN**

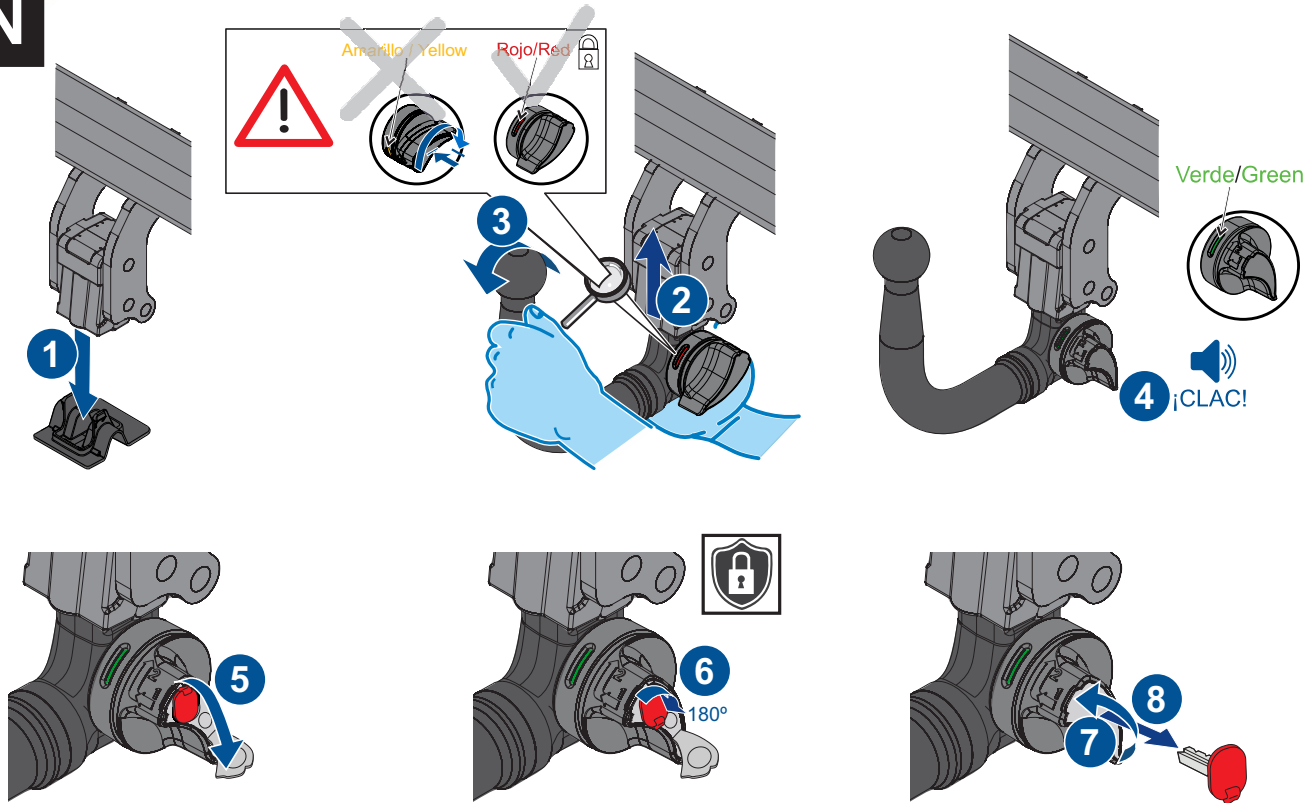

**OUT**

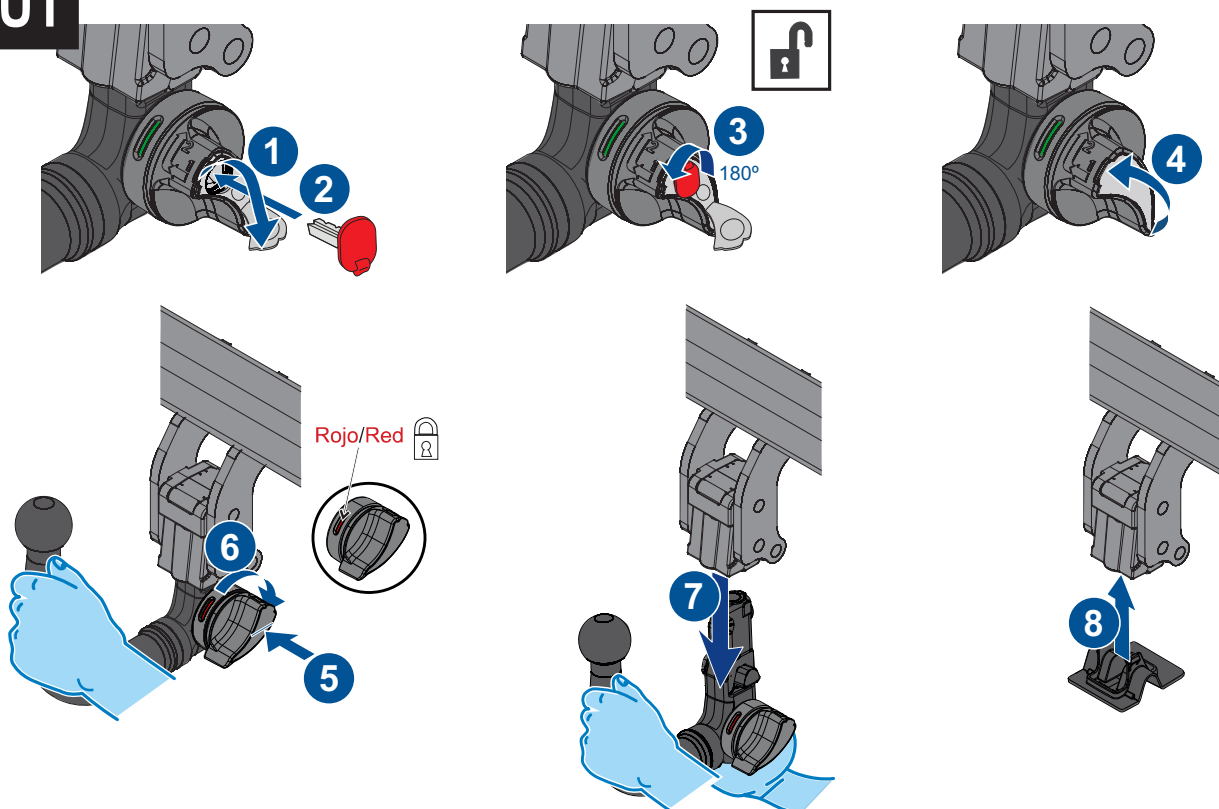



enganches

aragon

TowCar®



## ANEXO III

### CERTIFICADO DE TALLER

D. \_\_\_\_\_, expresamente autorizado por la empresa \_\_\_\_\_  
domiciliada en \_\_\_\_\_, teléfono \_\_\_\_\_, dedicada  
a la actividad de \_\_\_\_\_ n° de Registro Industrial \_\_\_\_\_ y n° de registro  
especial (1)\_\_\_\_\_.

#### CERTIFICA

Que la mencionada empresa ha realizado la/s Reforma/s y asume la responsabilidad de la ejecución,  
sobre el vehículo marca....., tipo.....  
variante..... denominación comercial .....  
matrícula ..... y n° de bastidor ....., de acuerdo con:

- La normativa vigente en materia de reformas de vehículos.
- Las normas del fabricante del vehículo aplicables a la/s reforma/s llevadas a cabo en dicho vehículo.
- El proyecto descriptivo de la/s reforma/s, adjunto al expediente.

#### OBSERVACIONES: (2)

Tipificada/s con el código de reforma/s.....  
Reforma consiste en:

#### COLOCACION DE ENGANCHE HOMOLOGADO EUROPEO MARCA:

\_\_\_\_\_

n° de identificación / marca de homologación:

Type :

Garantizo que se cumple lo previsto en el artículo 6 del Reglamento General de vehículos y, en su caso, en el artículo 9 del R.D. 1457/1986, de 10 de enero, por el que se regula la actividad industrial en talleres de vehículos automóviles, de equipos y sus componentes, modificado por 455/2010 de 16 de abril.

....., a.....de.....de .....

Firma y sello:

(1) En el caso de que la reforma sea efectuada por el fabricante se indicará N/A.

(2) Se debe especificar en este apartado OBSERVACIONES, la identificación de los equipos o sistemas modificados.

ES

1

ANEXO III  
CERTIFICADO DE TALLER



2



3



IT

1

DICHIARAZIONE DI CORRETTO MONTAGGIO

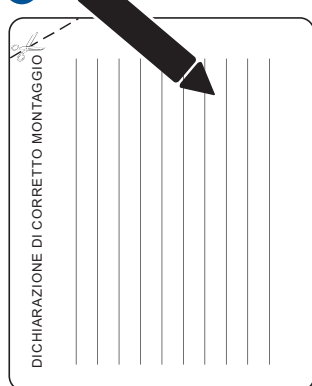

2

